

## Custom Valances - Special Designs

Conestoga offers a wide variety of arched panel configurations and options. Valances illustrated on the following pages represent popular custom arched panel designs. The manufacturing of custom valances is based off of customer-supplied dimensioned drawings. **If any of the following illustrations below match the look you desire, please copy the appropriate page, designate the necessary dimensions and forward it to Customer Service.**

- Arched panel valances are available in most mortise and tenon and miter designs. Applied moulding designs, while commonly available, depend on the radius of the panel.
- Design options include, but are not limited to all published panel raises and framing beads, edge profiles, grooved panels, wide framing, and custom rise dimensions.
- A CAD drawing will be created prior to the manufacturing of any custom arched panel. After a review and sign off by the customer, the drawing must be returned to Special Designs in order for production to begin. Lead-time calculations will not begin until Conestoga has received an approved drawing.
- Framing widths will match door style selected unless otherwise noted by customer.
- Please provide all necessary dimensions when ordering.

### Design Option A

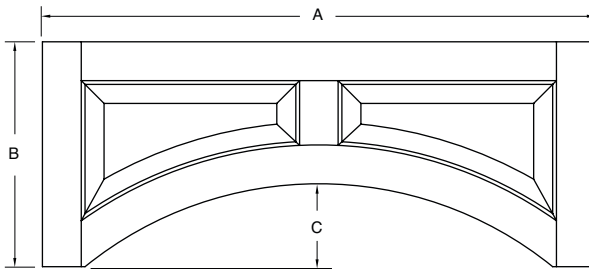

Sizes	
A	
B	
C	
Grain Direction	
Vertical	Horizontal

### Design Option B

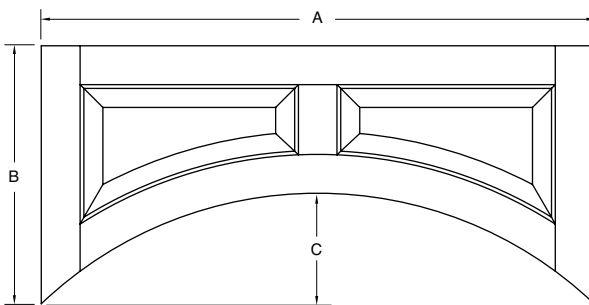

Sizes	
A	
B	
C	
Grain Direction	
Vertical	Horizontal

### Design Option C

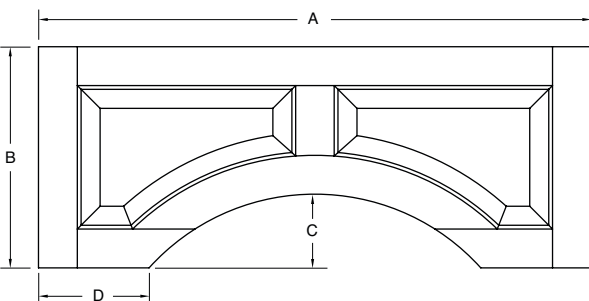

Sizes	
A	
B	
C	
D	
Grain Direction	
Vertical	Horizontal

**Custom Valances - Special Designs (continued)**

**Design Option D**

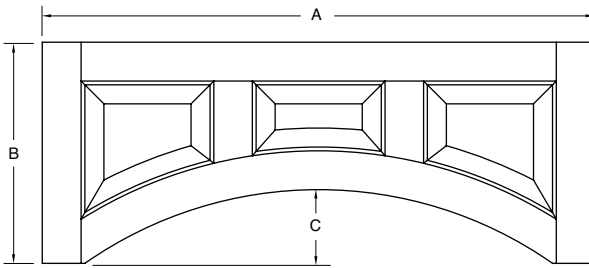

Sizes	
A	
B	
C	
Grain Direction	
Vertical	Horizontal

**Design Option E (horizontal grain only)**

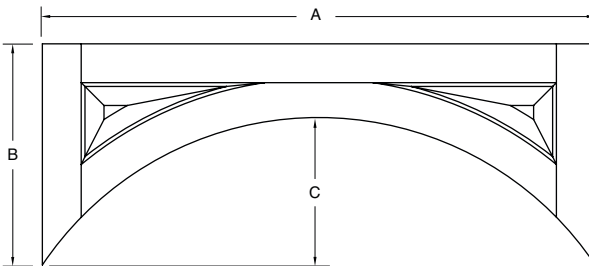

Sizes	
A	
B	
C	

Horizontal grain direction only.

**Design Option F**

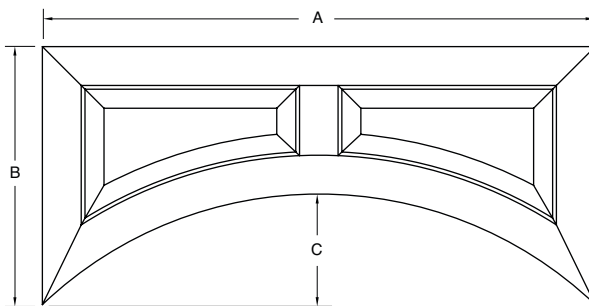

Sizes	
A	
B	
C	
Grain Direction	
Vertical	Horizontal

**Design Option G (applied moulding)**

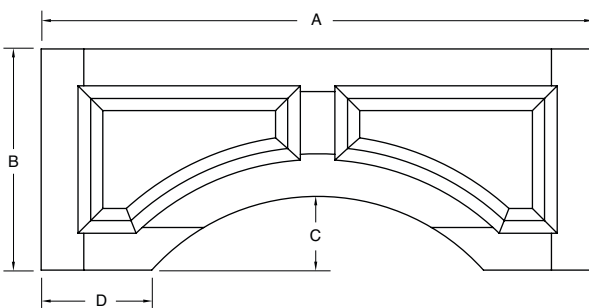

Sizes	
A	
B	
C	
D	
Grain Direction	
Vertical	Horizontal

**Design Option H (available with or without applied moulding)**

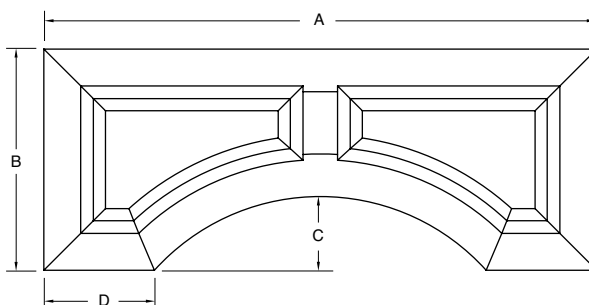

Sizes	
A	
B	
C	
D	
Grain Direction	
Vertical	Horizontal

## Standard Arched Valances

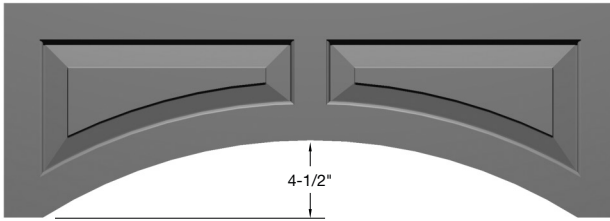

- Standard Arched Raised Panel Valances are available in three inch wide increments from 30" to 72" only.
- Minimum size – 30" wide x 12-1/2" high. Maximum size – 72" wide x 30" high.  
Framing widths: 2-3/4" stiles, 2-5/16" rails, 2-1/2" center stile. The rise is always 4-1/2", regardless of valance width.
- Horizontal grain panels are standard, vertical grain is available with a list per valance upcharge.
- Design standard as shown. Individual designs, including applied moulding, must be ordered through Special Designs.

Offering And Availability	
<b>Species</b>	
Material	All 3/4" and 1" species available except Rustic Knotty.
<b>Edge Profiles</b>	
pg 7.1	Machine Edge only.
<b>Framing Beads</b>	
pg 7.2	All 3/4" and 1" available.
<b>Panel Raises</b>	
pg 7.2A	All 3/4" and 1" available.
<b>Options</b>	
pgs 7.3-7.15	Available with pegs, distressing, cross grain sanding, wear sanding, putty pin holes, weathered grain and cut down in width only.

## Standard 1-Piece Valances

- 1-Piece Valances are available in 4-1/2" to 6" heights except Traditional Arch which is available in 6" height only.

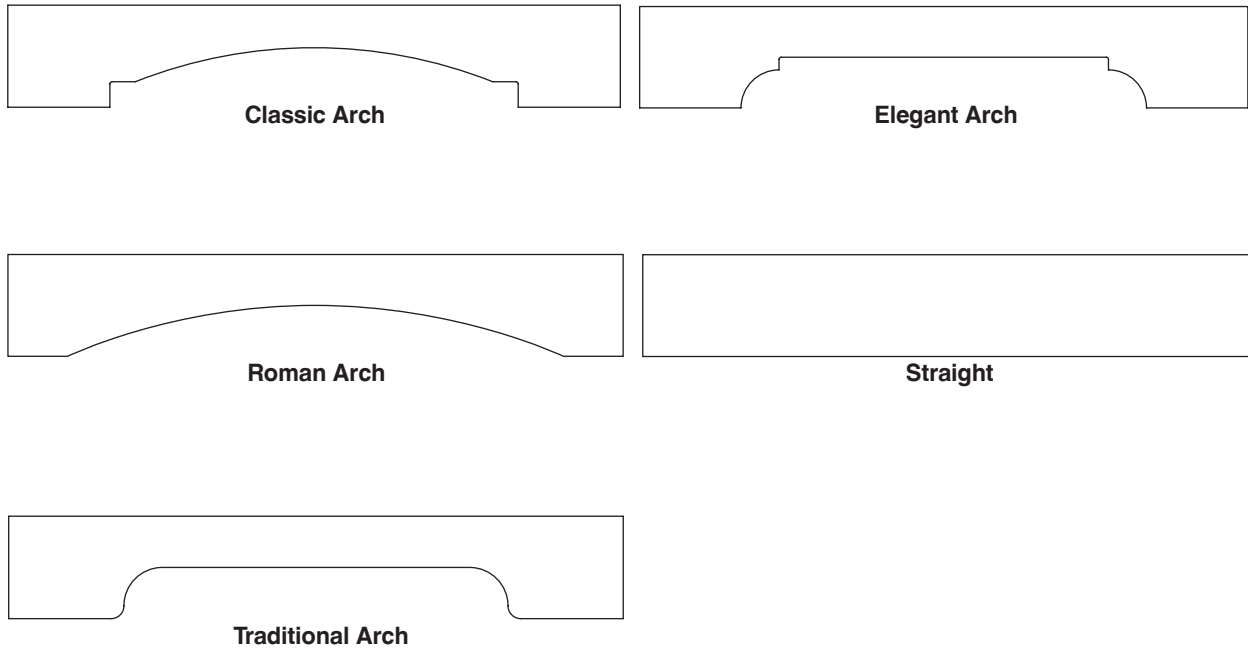

### Edge Profile Options

- Straight valance comes standard with Machine Edge, but is available with any edge profile. Specify which edges receive an edge profile, other than Machine Edge.
- Roman Arch valance and Traditional Arch valance come standard with Machine Edge. These valances are available with edge profiles: B-2, C-2, CFP-2, E-2, H-2, J-2, L-059, L-120, L-149, L-281, L-382, L-772, L-803, L-1160, LC-2, PRS-2, RC-2 and V-2. Specify which edges receive profiles other than Machine Edge.
- Classic Arch valance and Elegant Arch valance are available with a Machine Edge only.
- See matrix on next page to determine pattern related dimensions.

## Standard 1-Piece Valances (continued)

### Valance Matrix Instructions

Use the matrix below to determine the specifications for patterned valances. Find the desired valance length in one of the C rows. The top number (white numbers in black) in the column with the desired length is the pattern length. The pattern will be centered on the valance.

From the C block containing the desired overall valance length, the extreme right number in that row, which is under column B is the size of the flat areas on the left and right side of the pattern.

Example: If ordering a Traditional Arch valance with an overall length of 30" (dimension C), note that:

- 30" appears in the sixth C row, fourth column of the matrix.
- Referring to the top of the column, in row A, a pattern length of 19" will be found.
- Referring back to the 30" C row, at the right end of the row, in column B, flat areas of 5-1/2" on both the left and right ends of the valance will be found.
- The selected 30" valance will have a pattern 19" wide, centered on the valance, with 5-1/2" wide flat areas at both ends of the valance.

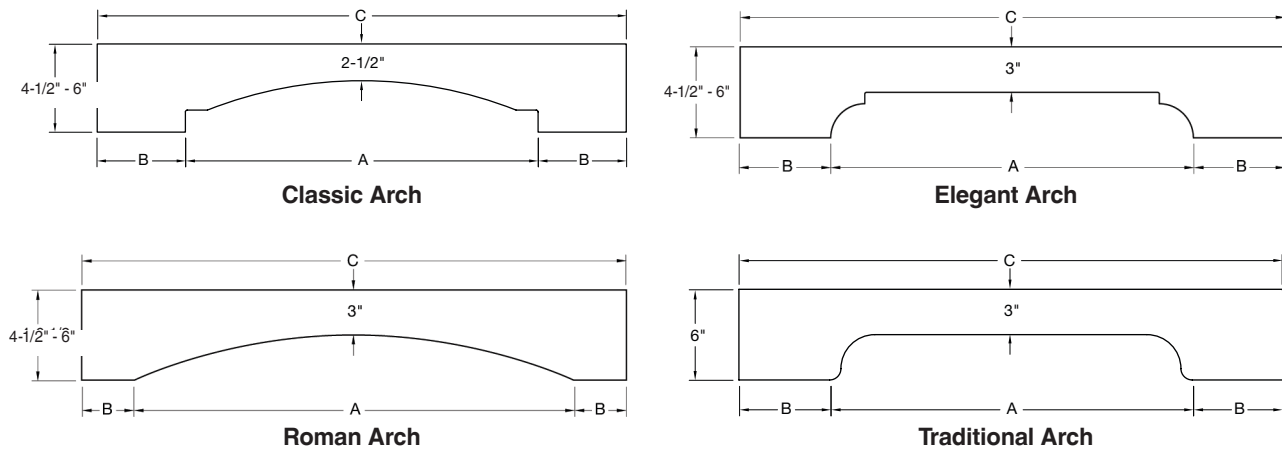

Valance Matrix											
A*	9"	11"	14"	19"	24"	30"	42"	54"	66"	78"	B
C	15"	17"									3"
C	16"	18"	21"	26"	31"	37"	49"	61"	73"	85"	3-1/2"
C		19"	22"	27"	32"	38"	50"	62"	74"	86"	4"
C		20"	23"	28"	33"	39"	51"	63"	75"	87"	4-1/2"
C			24"	29"	34"	40"	52"	64"	76"	88"	5"
C			25"	30"	35"	41"	53"	65"	77"	89"	5-1/2"
C					36"	42"	54"	66"	78"	90"	6"
C						43"	55"	67"	79"	91"	6-1/2"
C						44"	56"	68"	80"	92"	7"
C						45"	57"	69"	81"	93"	7-1/2"
C						46"	58"	70"	82"	94"	8"
C						47"	59"	71"	83"	95"	8-1/2"
C						48"	60"	72"	84"	96"	9"

\*Note: Dimensions above are based on a 6" height. Any increment 1/2" or less round down to nearest measurement in row "A". Any increment 9/16" or greater round up to nearest measurement in row "A".

## Slab Fillers



Slab Filler

- Slab fillers can be ordered in widths from 1-1/2" to 48" and heights from 4-1/2" to 96". Available in all 3/4" and 1" species.
- All 3/4" and 1" edge profiles are available.
- Slab fillers are available with pegs, radius corners, grooves, back-routed hand pulls, distressing, wear sanding and weathered grain.

11

Specialty Products

Any solid wood Slab products exceeding 35-15/16" in width (across the grain) will be quoted by Special Designs.

**\*100 to 119-15/16" specie availability:** 3/4" thick species include Cherry, Hard Maple, Hickory, Paint Grade Hard Maple, Quarter Sawn White Oak, Red Oak, Rift Cut White Oak, Rustic Knotty Cherry, Rustic Knotty Hard Maple, Soft Maple, Walnut and White Oak. 1" thick species (1" upcharge applies) include Cherry, Hard Maple, Red Oak and Soft Maple.

**†120" to 144" specie availability:** 3/4" thick species include Cherry, Hard Maple, Hickory, Paint Grade Hard Maple, Quarter Sawn White Oak, Red Oak, Rift Cut White Oak, Soft Maple, Walnut, White Birch and White Oak. 1" thick species (1" upcharge applies) include Cherry, Hard Maple, Paint Grade Hard Maple and Soft Maple.

## Glass Shelves



1/8" depth    1/4" depth

### Grafton

8" x 12"  
2" Framing

- Used in conjunction with a frame only door or a Wire Grille Insert.
- Allows light to flow through the entire cabinet, accentuating fine dinnerware, glassware or other collectibles.
- All 3/4" and 1" species available.
- Maximum size – 23-15/16" deep x 36" long.
- Edge profiles – defaults to machine edge on all 4 edges. Additional edge profiles include B-2, C-2, CFP-2, H-2, J-2, L-034, L-059, L-149, L-382, L-803, L-1160, LC-2 and PRS-2.
- Two framed options accept either 1/8" or 1/4" glass (glass not included).

## Fluted Fillers

**Tapered Flute**

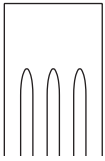

**Rounded Flute**

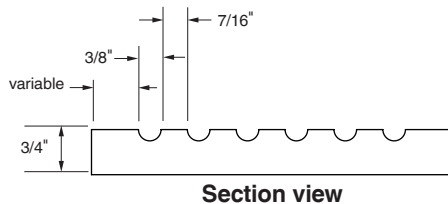
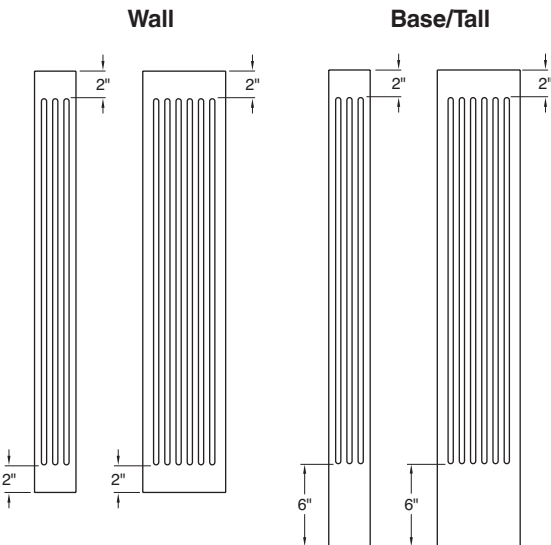
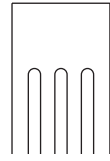

- Fluted Fillers can be ordered in custom widths from 3" to 15-15/16" and heights up to 96" in all standard 3/4" species.
- Choose from either Tapered or Rounded flutes. If not specified, flutes will be produced using the Tapered design.
- Non-fluted or "flat" areas are design specific, but can be customized to meet your design needs. Simply specify the flat dimensions desired. Specify "Flats to measure 0" to extend flutes the entire length of filler.
- 
- The number of flutes per filler width is indicated in the chart below. Custom flute spacing is available through Special Designs.

## Edge Profile Options

- Fluted Fillers come standard with a Machine Edge, but can be ordered with a variety of edge profiles including B-2, C-2, LC-2, L-034, L-059, L-149, L-253, L-382, L-686, L-1160, PRS-2, RC-2 and V-2.
- Beveled edge profile selections include the L-991 (45 degree back bevel) and the L-423 (22-1/2 degree back bevel).
- Premium edge profiles include the L-297, L-304 and LC-Inset edge. Upcharge applies.

## Wood Floating Shelves

The Floating Shelf is a functional way to add style to the interior décor of kitchens, bathrooms and other living areas throughout a home. These shelves have a support frame that must be mounted securely to the studs in the wall, then the exterior portion of the shelf slides over the support frame to completely conceal the sub-structure. The result is an attractive, fashionable shelf to display pictures, dishware and other interior design accents.

### Mini Plain, Plain, Beaded and Crown Floating Shelves

- Available species include Cherry, Hard Maple, Paint Grade Hard Maple Hybrid, Quarter Sawn White Oak, Rift Cut White Oak, Red Oak and Walnut.
- The front and sides of the shelves are made from 3/4" solid hardwoods, mitered at the two front corners.
- The Beaded Floating Shelf includes a decorative bead on both the top and bottom of the front and side returns.
- The Crown Floating Shelf includes a modified crown moulding on the front and side returns.
- The shelf top and bottom is 3/8" thick plywood, matching the specie of the hardwood, except for Paint Grade Hard Maple Hybrid, which uses 3/8" MDF for the shelf top and bottom.
- Once the Floating Shelf is fully installed, it is recommended that the shelf be secured to the support frame using headless pins or small finishing nails so the shelf cannot inadvertently slide off of the support frame.
- Custom lengths available.

### Support Frame

- Manufactured using 3/4" thick unselected hardwoods.
- It is imperative that Floating Shelves be mounted to the recommended number of wall studs using two or more coarse thread screws at least 2-1/2" in length per stud. The 6" and 12" Floating Shelves should be mounted to one or more wall stud, the 24" to 48" Floating Shelves should be mounted to two or more studs, the 60" Floating Shelf should be mounted to three or more studs, the 72" and 84" Floating Shelf should be mounted to four or more studs.
- Maximum load capacity for the shelf and support frame is 10 lbs. per linear foot. While Floating Shelves are built from strong, sturdy materials, the load capacity of these shelves is dependent upon the quality of the installation screws and whether the shelves are secured into the wall studs. If not secured into the recommended number of studs using two or more high quality installation screws per stud, the shelf may not support the desired weight. Conestoga will not be responsible for shelf failure due to inadequate installation techniques or materials.
- All models of Wood Floating Shelves are available with primers, wiping stains, Truetones, Colourtones, Prism Paints and glazes.

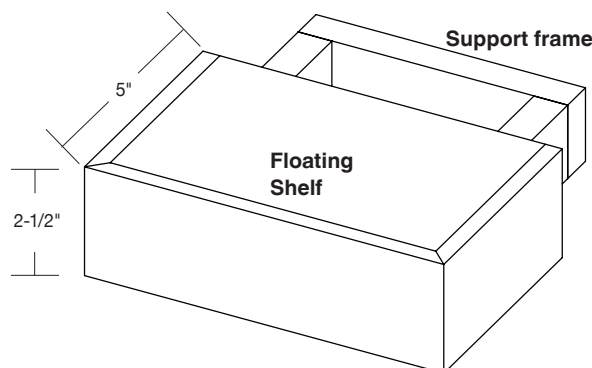



Wood Floating Shelves (continued)

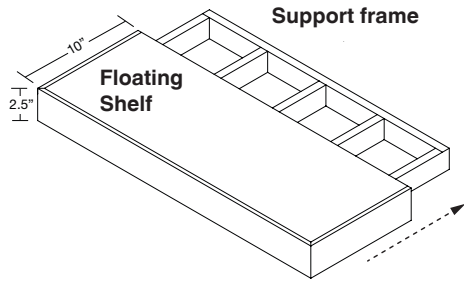

Plain Floating Shelf							
Specie	24" or 30"	36"	42"	48"	60"	72"	84"
Cherry							
Hard Maple							
PG Hard Maple Hybrid							
Quarter Sawn White Oak							
Rift Cut White Oak							
Red Oak							
Walnut							

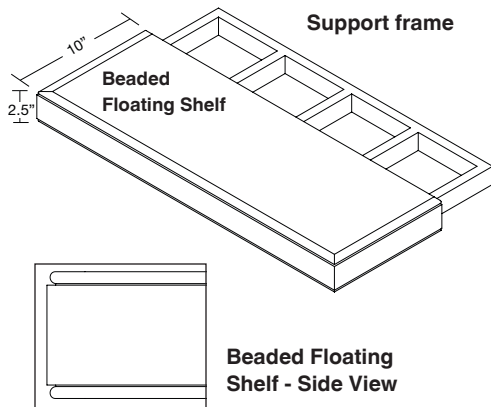

Beaded Floating Shelf							
Specie	24" or 30"	36"	42"	48"	60"	72"	84"
Cherry							
Hard Maple							
PG Hard Maple Hybrid							
Quarter Sawn White Oak							
Rift Cut White Oak							
Red Oak							
Walnut							

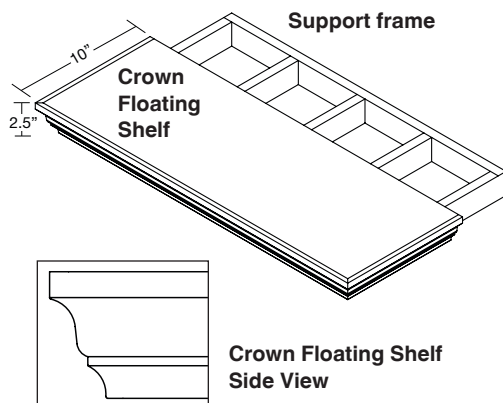

Crown Floating Shelf							
Specie	24" or 30"	36"	42"	48"	60"	72"	84"
Cherry							
Hard Maple							
PG Hard Maple Hybrid							
Quarter Sawn White Oak							
Rift Cut White Oak							
Red Oak							
Walnut							

## Wood Floating Shelves (continued)

### L-Style Wood Floating Shelves

The L-Style Wood Floating Shelf is a functional way to add style to the interior décor of kitchens, bathrooms and other living areas throughout a home. These shelves include two-part reinforced nylon support clips that must be securely mounted to the shelf itself and to the studs in the wall. The support clips interlock, completely concealing the mounting hardware. The result is a sturdy, attractive, and fashionable shelf to display pictures, dishware and other interior design accents.

#### L-Style Wood Floating Shelf

- The shelf is produced from solid hardwoods and is shipped assembled and ready to be installed.
- The back of the shelf is routed out along nearly the length of the entire shelf so that the support clips can be installed where needed to align with the available wall studs and remain fully concealed after installation.

- Custom lengths available.

#### • Support Clips

- Manufactured using high strength reinforced nylon.
- Clips are designed to interlock and are extremely strong and durable.
- Mounting fixtures are secure and concealed.
- Secure clips to the L-Style shelf using #8 pan head screws.
- It is imperative that support clips be mounted to two or more wall studs using four or more coarse thread screws at least 2-1/2" in length.
- Installation jigs are provided to aid with positioning the clips correctly to the shelf and wall studs.
- Maximum load capacity for the shelf and support clips is 10 lbs. per linear foot. While L-Style Floating Shelves are built from sturdy hardwood materials, the load capacity of these shelves is dependent upon the quality of the installation screws and whether the support clips are properly secured into the shelf and wall studs and the support clips are interlocked properly. If the support clips are not secured to the shelf properly, or the shelf is not secured into two or more studs using two or more high quality installation screws per stud, the shelf may not support the desired weight. Conestoga will not be responsible for shelf failure due to inadequate installation techniques or materials.
- L-Style Wood Floating Shelves are available with primers, wiping stains, Colourtones, Prism Paints and glazes.

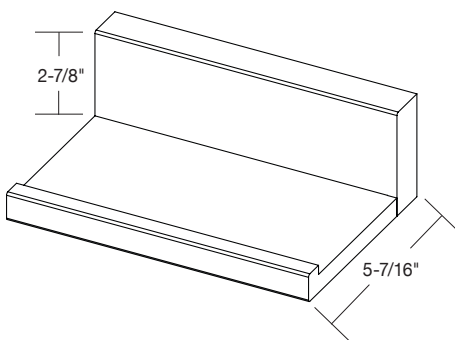

L-Style Floating Shelf					
Specie	24"	30"	36"	42"	48"
Cherry					
Hard Maple					
PG Hard Maple					
Red Oak					
White Oak					
Walnut					

## Alternative Material Floating Shelves (continued)

11

Specialty Products

### Super Matte Floating Shelves

- ◆ Available in select Super Matte colors
- ◆ The front and sides of the shelf are made from 3/4" edgebanded material, mitered at the two front corners.
- ◆ The shelf top and bottom is 6mm thick Super Matte material.
- ◆ Once the Floating Shelf is fully installed, it is recommended that the shelf be secured to the support frame using headless pins, small screws or small finishing nails so the shelf cannot inadvertently slide off of the support frame.
- ◆ Custom lengths available

### Support Frame

- ◆ Manufactured using 3/4" thick unselected hardwoods.
- ◆ It is imperative that Floating Shelves be mounted to two or more wall studs using four or more coarse thread screws at least 2-1/2" in length. The 60" Floating Shelf should be mounted to three or more studs.
- Maximum load capacity for the shelf and support frame is 10 pounds per linear foot. While Super Matte Floating Shelves are built from strong, sturdy materials, the load capacity of these shelves is dependent upon the quality of the installation screws and whether the shelves are secured into the wall studs. If not secured to two or more studs using two or more high quality installation screws per stud, the shelf may not support the desired weight. Conestoga will not be responsible for shelf failure due to inadequate installation techniques or materials.

Super Matte Floating Shelf					
Colors	24" or 30"	36"	42"	48"	60"
Anthracite Matte, Black Matte, Light Grey Matte, White Matte					

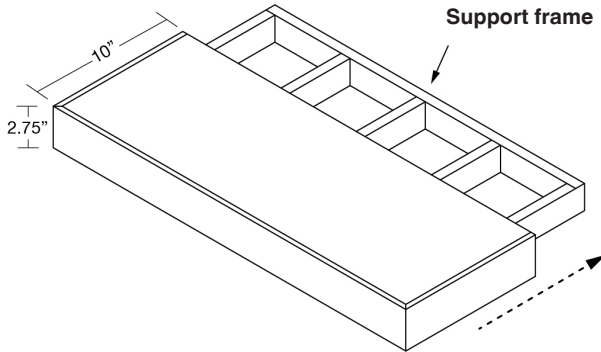

## Alternative Material Floating Shelves (continued)

### Thermally Textured Surface Floating Shelves

- ◆ Available in all Intrigue, Strata and Vogue TTS materials
- ◆ The front and sides of the shelf are made from 3/4" banded TTS material, mitered at the two front corners.
- ◆ The shelf top and bottom is 8mm thick TTS material, except Intrigue which utilizes 1/4" material.
- ◆ Once the Floating Shelf is fully installed, it is recommended that the shelf be secured to the support frame using headless pins, small screws or small finishing nails so the shelf cannot inadvertently slide off of the support frame.
- ◆ Custom lengths available

### Support Frame

- ◆ Manufactured using 3/4" thick unselected hardwoods.
- ◆ It is imperative that Floating Shelves be mounted to two or more wall studs using four or more coarse thread screws at least 2-1/2" in length. The 60" Floating Shelf should be mounted to three or more studs.
- Maximum load capacity for the shelf and support frame is 10 pounds per linear foot. While TTS Floating Shelves are built from strong, sturdy materials, the load capacity of these shelves is dependent on upon the quality of the installation screws and whether the shelves are secured into the wall studs. If not secured to two or more studs using two or more high quality installation screws per stud, the shelf may not support the desired weight. Conestoga will not be responsible for shelf failure due to inadequate installation techniques or materials.

Strata Floating Shelf					
Tier 1	24" or 30"	36"	42"	48"	60"
Aspen Oak (LM67), Barn Oak (LN27), Bianco (BO11), Carbone (LM08), City Oak (LM69), Graphite (LG18), Oregon Pine (LK84), Palissandro (LK55), Swiss Almond (LM96), Vineyard Oak (LN30)					
Tier 3					
Burned (SO12), Cypress Point (SO13), Light Carbon (SO15), Nero (U129), Silver Sand (SO11)					

Vogue Floating Shelf					
Colors	24" or 30"	36"	42"	48"	60"
Fresno Glacial (16N), Nogal Slow (5AE), Roble Aurora (98V), Roble Azabache (75V), Roble Colorado (97V), Roble Denver (84V), Roble Eternity (4AE), Roble Joplin (17N), Roble Stella (74V)					

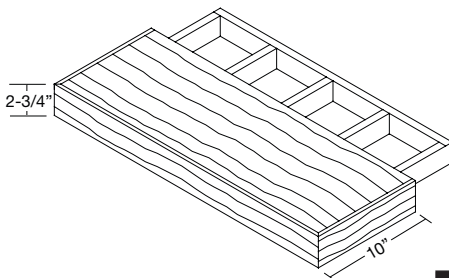

Intrigue Floating Shelf					
Colors	24" or 30"	36"	42"	48"	60"
Carbon Frozen Wood (H1292), Grey Vicenza Oak (H3158), Natural Carini Walnut (H3710), Stone Grey Frozen Wood (H1288), White Frozen Wood (H1290)					

## Alternative Material Floating Shelves (continued)

### Decorative Laminate Veneer Floating Shelves

- Available in all Allure colors
- The front and sides of the shelf are made from 3/4" banded DLV material, mitered at the two front corners.
  - Bright White and White Dove, front of shelf and edges are manufactured using 19mm DLV board; Canadian Grey, Clearwater Oak, Dering Forest, Helena Walnut, Monaco, Ocala Walnut, Sabine Walnut, Valley Forge Elm, White Chocolate and White Cypress. Shelves are manufactured using DLV center panel material sandwiched to 1/2" MDF, then edgebanded. Interior of sandwiched material is raw MDF.
- The shelf top and bottom utilizes DLV center panel material.
- Once the Floating Shelf is fully installed, it is recommended that the shelf be secured to the support frame using headless pins, small screws or small finishing nails so the shelf cannot inadvertently slide off of the support frame.
- Custom lengths available

### Support Frame

- Manufactured using 3/4" thick unselected hardwoods.
- It is imperative that Floating Shelves be mounted to two or more wall studs using four or more coarse thread screws at least 2-1/2" in length. The 60" Floating Shelf should be mounted to three or more studs.
- Maximum load capacity for the shelf and support frame is 10 pounds per linear foot. While DLV Floating Shelves are built from strong, sturdy materials, the load capacity of these shelves is dependent on upon the quality of the installation screws and whether the shelves are secured into the wall studs. If not secured to two or more studs using two or more high quality installation screws per stud, the shelf may not support the desired weight. Conestoga will not be responsible for shelf failure due to inadequate installation techniques or materials.

Allure DLV Floating Shelf

Colors	24" or 30"	36"	42"	48"	60"
Bright White					
White Dove					
Canadian Grey					
Clearwater Oak					
Dering Forest					
Helena Walnut					
Monaco					
Ocala Walnut					
Sabine Walnut					
Valley Forge Elm					
White Chocolate					
White Cypress					
Skye					

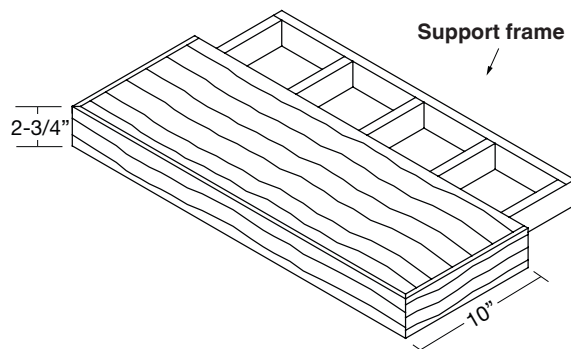

## Stemware Holders

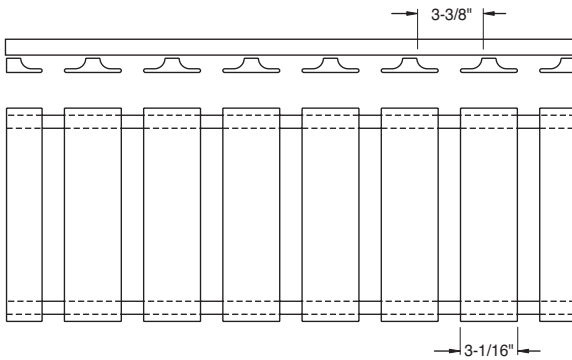

- Stemware holders are available in Cherry, Hard Maple and Red Oak.
- 30" (7 slots) or 36" (8 slots) lengths.
- Spacing between slats:  
30" stemware holder – 1-1/8".  
36" stemware holder – 1-3/8".
- Depth 11-1/4".
- Thickness 1-1/2".
- Accommodates most stemware styles.
- Available unfinished or finished.

## Custom Cutting Boards

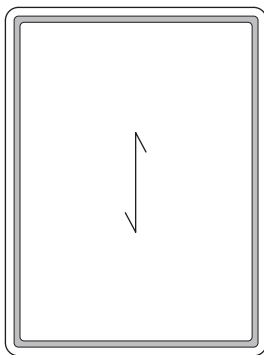

**1-Piece Slab**

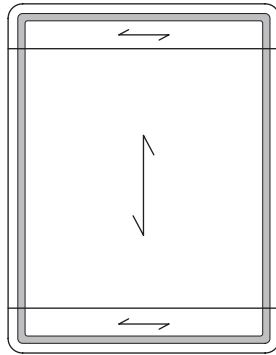

**3-Piece Slab**

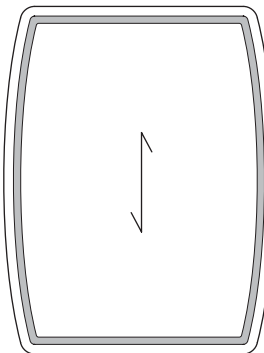

**1-Piece Barrel**

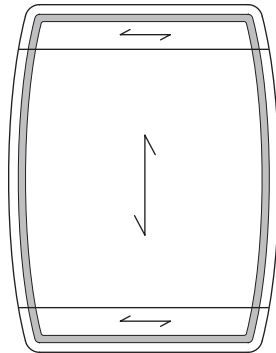

**3-Piece Barrel**

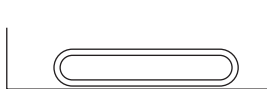

Hand Pull - 1/4" deep,  
3-1/2" long, 1/2" wide



Drip Groove - 5/32" deep

- Cutting boards are available in all published species except Rustic Knotty.
- Cutting boards available in 3/4" and 1" thickness.
- Minimum size for all styles is 10" x 10", maximum size is 18" x 22".
- All designs include 3/4" radius corners and 3/32" radius edges.
- 3-Piece designs are made using 2-5/16" wide rails on face (horizontal grain) with pinless construction.
- All cutting boards have a routed drip groove into the face of the board to collect liquids.
- No oils or finishing treatments will be applied by Conestoga.
- Care instructions for wood cutting boards:
  - ♦ Treat wood with butcher block oil or mineral oil only.
  - ♦ To clean, wipe with a mixture of warm water and a mild dish detergent. Never submerge cutting boards in water or place in dishwasher.
- Hand pull option on back of cutting board is available: per pull.
- Due to repetitive exposure to liquids, cutting boards will not be warranted against bowing, warping, splitting or twisting.

## Front Frame Specifications

- Double dowel construction on standard width framing.
- Material will be Standard grade unless otherwise noted. Premium grade available, upcharges apply.
- Standard framing width is 1-1/2"; additional widths available, upcharges apply.
- 3/4" framing thickness standard; 1" thick material is available, upcharges apply.
- Minimum framing width 3/4"; 15/16" for front frames with an edge profile.
- Material surfaced on four sides.
- Assembled frames sanded on front only with 220 grit sandpaper.
- Maximum front frame sizes are 120" in one direction and 48" in the other direction. For example, a front frame can be ordered 48" x 120" or 120" x 48" but not 120" x 120".
- Framing wider than 4-1/2" may have one glue joint. Framing wider than 6-1/2" may have two glue joints.
- Minimum glue-in trimmable insert width is 1/2"; maximum glue-in trimmable insert width is 3".

### Front Frame Tolerances

- A tolerance of +/- 1/32" is considered acceptable on front frame exterior and interior opening dimensions.
- A tolerance of +/- 1/16" out of square is considered acceptable on all front frames.
- 1/32" offset on frame back at any joint is considered acceptable.
- 1/64" offset at any exterior joint on the outside perimeter is considered acceptable.

### Front Frame Ordering Information

- Conestoga's custom front frames can be ordered as beaded, non-beaded or profiled. To specify, check the appropriate box in the beaded area of the order form.

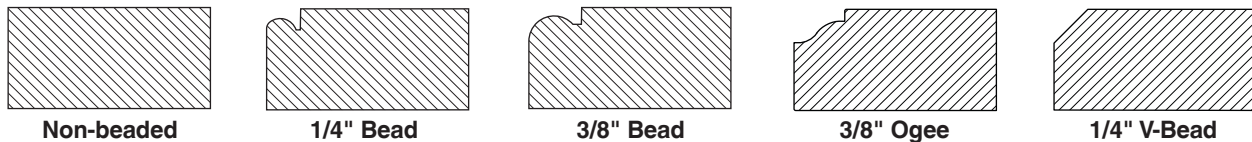

- Front frame exterior dimensions, interior opening dimensions and framing widths can be ordered to the nearest 1/16".
- On beaded orders, customers may select specific openings to be "non-beaded" by specifying the opening letter designation. Example: "Do not bead opening S."
- When ordering custom front frames for Conestoga Cabinet Systems, all framing and opening sizes must be specified by the customer. Only standard groove locations available.
- Front Frame Configuration Template Packet can be found on the Customer Business Portal. Contact Customer Service for sign on information or, request the Front Frame Configuration Template Packet.

## Front Frame

Material				
Specie	1 or 2	3 or 4	5 or 6	7 or 8
Alder				
Bamboo				
Birch, Red				
Birch, White*				
Cherry*				
Hickory*				
Maple, Hard*				
Paint Grade Hard Maple				
Maple, Soft				
Oak, Red*				
Oak, White*				
Pine, Knotty				
Walnut*				

Options	
Option	
Premium grade material (subject to availability)	
1" thick framing (Bamboo not available)	
Face and back sand	
Beaded inset framing (1/4" or 3/8" bead)	
Ogee or V-Bead framing	
Pre-fit inset door or drawer front	
Groove to fit Conestoga Cabinet Systems	
Edge profile around outside perimeter	
Glue-in trimmable inserts	
Cut Backs	
Roman shaped rails - non-beaded	
Beaded shaped rails available through Special Designs	
Oversize front frame assembly Tier 1: 58" to 99-15/16" in width and height	
Oversize front frame assembly Tier 2: 100"+ in width or height	
Oversize front frame sanding (frames exceeding 48" in width or height)	
Unassembled front frames	



## Front Frame (continued)

Non-Standard Framing Widths	
Material Width	Upcharge per stile or rail
3/4" to 1-7/16"	
1-1/2"	
1-9/16" to 5-15/16"	
6" to 7-7/16"	
7-1/2" and wider	







Front Frames Lead-Times			
Product	Standard Lead-Time	Expedite max. 6 frames	
		Code Red	Code Blue
Custom front frames	10	2	5
Options - additional working days			
Shaped rail	3	3	3
Pre-fit inset doors	2	2	2



Non-standard frame configurations will be processed through Special Designs.

Orders containing products with different lead-times are given the longest lead-time date.

### Inset Door and Drawer Front Information

- The following edge profile options are recommended for use with inset doors and drawer fronts.
- These edges have a 5 degree back bevel edge to ensure sufficient door clearance. Machine Edge and L-149 are available upon request at no additional upcharge.
- Front frames ordered with inset doors and drawer fronts will be pre-fit to the opening size. A 3/32" margin will be used on all sides for single doors and drawer fronts and between butt door pairs.

Standard Edge Profile Options	
 <b>L-253</b>	 <b>L-686</b>
 <b>L-947</b>	 <b>L-967</b>
 <b>L-1117</b>	 <b>L-1120</b>

Premium Prefit/Inset Edge Profiles
additional charge per door or drawer front. (These 2 profiles require 2 additional working days.)
 <b>L-304</b>
 <b>L-996</b>

### Design Exceptions

- The following door and drawer front styles are not available for inset applications due to their unique design characteristics: 1-1/8" Sandwich Drawer Front, #10 Drawer Front, 10141 Drawer Front, Alexandria, Aspen, AspenPP, Astoria, Aurora, Boulder, BoulderPP, CRP-1420, CRP-10191, CRP-10318, CRP-10334, CRP-10827, CRP-10875, CRP-10946, Fairhaven, Fargo, FargoPP, Hastings, Juno, Keystone Drawer Front, LaSalle, Marcel Drawer Front, Omaha, OmahaPP, Prestige, Rothbury, Rothsford, Savoy, Topeka, TopekaPP, TW-10827 and Venus.
- Alternative Material doors and drawer fronts are not available for inset applications, including Allure DLV, Intrigue TTS, Strata TTS, Vogue TTS, Synchronicity High Gloss and Super Matte products.
- Openings with trimmable inserts are not available beaded.
- L-253 and L-686 – only edge profiles available in MDF pre-fit products.
- Finished front frames are not available with antiquing or wear sanding.
- Distressed front frames will receive a modified distressing package.

## Inset Door and Drawer Front Information (continued)

---

- Custom front frames that are ordered with Colourtones and glazes will receive the same hand glazed finishes as doors. Cabinet Systems parts that are ordered with Colourtones and glazes will be finished with the special Colourtones that have been tinted to match the Colourtones and glaze combination. They will not receive a hand rubbed glaze.

### Inset Option with Miter Designs Not Recommended

Only miter door designs with edge profile options are available with the inset option; however, miter designs are not recommended with the inset option. The following issues are associated with inset miter designs, and will not be considered defective:

- ♦ **Miter joint lines may not intersect door corner after pre-fit sanding.** This is not considered a defect as it is a necessary part of the pre-fit process to ensure the proper fit within the frame openings. This condition may not be pleasing to some customers.
- ♦ **Panel expansion caused by high humidity may cause miter doors to bind inside frame openings.** Although Conestoga's miter door joint construction is one of the most durable in the industry, high humidity will cause solid wood center panels to expand in width. This pressure can result in framing pushing outward and creating a "barrel" effect where the framing rubs against the front frame.
- ♦ If a miter design is selected, it is highly recommended that doors and drawer fronts be manufactured as 5-piece MDF, Hybrid products with MDF center panels or with plywood center panels. These materials will reduce the likelihood of product expansion and binding of inset doors within the front frame. While reducing the possibility of binding, expansion of solid wood framing can still occur and will not be considered defective.

## 1/8", 1/4" and 3/4" Plywood Program

---

- 1/8" thick sheet stock with Grade A face veneer applied over veneer core with sound back.
- 1/4" thick sheet stock with Grade A face and #1 back veneers applied over MDF core.
- 3/4" thick sheet stock with Grade A face veneer applied over veneer core with prefinished Natural Birch back, except where otherwise noted.
- 3/4" thick full sheets or cut-to-size panels over 96-1/16" up to 120" in length of Hard Maple/Hard Maple will have an MDF core.
- All 1/8", 1/4" and 3/4" sheet stock is available in full 4' x 8' sheets, with the exception of Hard Maple/Hard Maple which is also available in 4' x 10' sheets. All sheet stock including 4' x 10' material is also available as cut-to-size panels.
- Plywood finished in Colourtones may have pin marks and small scratches from drying racks, veneer checks, seam separation, glaze smudges, fingerprints, overspray and some dirt in topcoat. Such defects will be kept to a minimum, but are unavoidable when finishing large parts and will not be considered defective. 3/4" thick edges will not be finished unless edgeband has been applied.
- Lead-time 5 days cut-to-size, unfinished; 3 days for full sheets. Add 5-6 days for finishing.
- Additional sheet stock is available through Special Designs in common species, grades and thickness in single sheet minimums. Specify thickness, core type, specie (face and back), veneer grade (face and back) and veneer cut (face and back). Lead-times are subject to availability.
- Oversized packaging charge of per item applies for large cut-to-size pieces or full 4' x 8' sheets of 1/8", 1/4" or 3/4" material. Oversize packaging parameters and conditions apply when the size exceeds 36" wide and 36" long, if any dimension exceeds 84", or when a customer requests oversize packaging.

**1/8", 1/4" and 3/4" Plywood Program (continued)**

**Options**

- When ordering cut-to-size plywood, specify width, height and grain direction.
- Edgeband charges (3/4" plywood only):
  - ◆ .5mm edgeband 1 to 4 edges: per panel.
  - ◆ 2mm edgeband 1 to 4 edges: per panel.
  - ◆ For edgeband on specific edges of cut-to-size plywood, specify edges as follows: top, bottom, left, right or all edges.
- Grooving available (1/4" material only):
  - ◆ G-012, G-015 or G-056 groove profiles.
  - ◆ Spacing available in increments starting at 1/2" up to 4".
- When ordering primed or painted 3/4" cut-to-size MDF panels, exterior edges will not be profiled, sanded or prepped for finishing and panel edges will appear somewhat porous. To receive edges that are profiled and sanded prior to finishing, order as a Slab door design with the Machine Edge profile.
- Panel Grooving charges (per panel):
  - ◆ Up to 24" wide and 48" or under in length.
  - ◆ Up to 24" wide and over 48" in length
  - ◆ Over 24" wide and 48" or under in length.
  - ◆ Over 24" wide and over 48" in length.
- Cut-to-size or full sheets of plywood also available finished; see Finishing Program Section for finish options
- Colourtone finishes are available on Cherry, Hard Maple and Red Oak plywood only.

1/8" Plywood Panel Program		
Specie		
Cherry		
Maple, Hard		

1/4" Plywood Panel Program		
Specie		
Alder		
Bamboo, Caramelized		
Birch, Red		
Birch, White		
Cherry		
Hickory		
Maple, Hard		
MDF (Raw)		
Oak, Red		
Oak, White		
Oak, White, Quarter Sawn		
Oak, White, Rift Cut		
Walnut		

3/4" Plywood Panel Program		
Specie (Exterior/Interior)		
Alder/Natural Birch (UV Finish, Veneer Core)		
Bamboo, Caramelized/Bamboo (Composite Core)		
Cherry/Cherry (Veneer Core)		
Cherry/Natural Birch (UV Finish, Veneer Core)		
Hard Maple/Hard Maple (Veneer Core)		
Hard Maple/Natural Birch (UV Finish, Veneer Core)		
MDF (Raw)		
Red Oak/Red Oak* (Veneer Core)		
Red Oak/Natural Birch* (UV Finish, Veneer Core)		
Rift Cut White Oak/Rift Cut White Oak (Composite Core)		
Walnut/Walnut (Composite Core)		

\*Available with .5mm edgebanding only.

## 1/4" Short Grain Plywood Program

- 96" x 48" panel for island back or wall panel applications.
- Grain runs vertically in the 48" direction.
- 1/4" thick material with Grade A face veneers applied over MDF core with sound back.
- Available unfinished or finished; see Finishing Program Section for finish options
- Lead-time 3 days unfinished, add 5-6 days for finishing.
- Oversize packaging fee applies.

### 1/4" x 96" x 48" Plywood Short Grain Panel

Part #	Specie	
1600121A	Cherry	
1600122A	Maple, Hard	

## Veneers

- All veneers are approximately 1/32" thick and have real wood veneer faces.
- One end and one side of any veneer sheet is guaranteed to be free from physical damage.
- Wood back veneers have a cross grain wood backer which allows trim edges to be finished to reduce "black line" effect.
- Poly back veneers are applied to a polymer resin impregnated membrane. They contain no added urea formaldehyde (NAUF), are rigid yet pliable and provide excellent moisture resistance.
- Wood back and Poly back veneers are available with their applicable backer with an optional pressure sensitive adhesive (PSA) backer. PSA backed veneers have a pre-glued adhesive layer protected by a peel coat covering that must be removed prior to application.
- Phenolic Back veneers will be used in place of 48-1/4" x 96-1/2" Wood back or Poly back when ordered with Colortones, Prism Prints or primers. Upcharge applies.
- Veneers are not guaranteed to perfectly match solid wood doors. Veneer is sliced from premium material; color and grain match will be more uniform than solid wood doors. Hickory veneers may contain mineral streaks and peck marks.
- Proper surface conditions and preparation is essential to successful application and performance of veneered surfaces.
- Per manufacturer's recommendations, veneers of all backer types should be placed flat and allowed to acclimate 48 hours before installation.
- Pressure sensitive veneers should not be applied to bare wood or surfaces covered with sanding sealers, high pressure laminates, melamine or other plastic materials.
- Wood back and Poly back veneers are best applied with roller grade adhesives. Sufficient adhesive coverage on both the veneer and substrate surface will ensure proper adhesion and performance.
- Conestoga is not liable for product failure due to improper surface preparation, adhesive selection or installation technique.
- Finishing Option available. Stained veneers may vary slightly in color from solid wood products of the same specie. Finishing adds 5-6 days to standard lead-time.
- Conestoga does not accept returns of veneers.

### PSA Wood Back

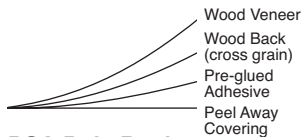

### PSA Poly Back

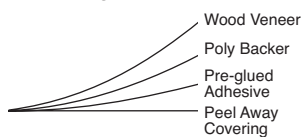

### Wood Back

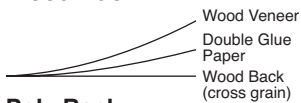

### Poly Back



### Phenolic Back



Specie	24" x 96" PSA Veneers		48-1/4" x 96-1/2" Veneers		
	Wood Back	Poly Back	Wood Back	Poly Back	Phenolic Back*
Alder	Yes	Yes	Yes	Yes	NA
Bamboo	Yes	Yes	Yes	Yes	NA
Birch, Red	Yes	Yes	Yes	Yes	NA
Birch, White	Yes	Yes	Yes	Yes	NA
Cherry	Yes	Yes	Yes	Yes	NA
Hickory	Yes	Yes	Yes	Yes	NA
Maple, Hard	Yes	Yes	Yes	Yes	Yes
Oak, Red	Yes	Yes	Yes	Yes	NA
Oak, White	Yes	Yes	Yes	Yes	NA
Pine, Knotty	Yes	Yes	Yes	Yes	NA
Oak, White, Quarter Sawn	Yes	Yes	Yes	Yes	NA
Oak, White, Rift Cut	No	No	Yes	No	NA
Walnut	Yes	Yes	Yes	Yes	NA

Stock item, 3 to 4 day lead-time.  Non-Stock item, 12 to 16 day lead-time.

\* Available with primers, Colourtone and Prism Paint finishes only.

## Wood Edgeband Program

Conestoga offers 7/8" wide x 500' rolls of .5mm wood edgeband to complete your panel processing requirements. Select species are also offered in 250' rolls. See charts below for specie availability.

- Real wood veneer applied to an unglued fleece backer.
- Edgeband is not guaranteed to perfectly match solid wood doors or sheet stock. Veneer edgeband is sliced from premium material; color and grain match will be more uniform than solid wood doors.
- Edgeband will contain multiple splice joints which will not be considered a defect.
- Conestoga is not liable for product failure due to improper surface preparation, adhesive selection or installation technique.
- All Conestoga finishing options are available as outlined in the Finishing Program Section of this manual.
- Lead-time 5 days unfinished for stock species, add 5-6 days for finishing. Expedite lead-times not available.
- Conestoga does not accept returns of finished edgeband.

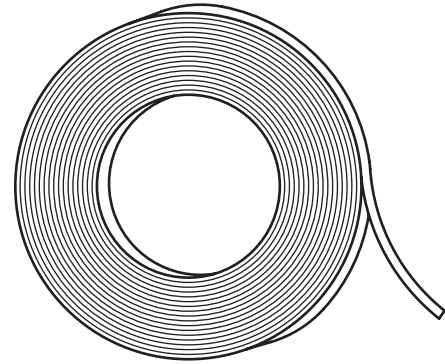

500' Wood Edgeband	
Specie	Specie
Alder	Maple, Hard
Bamboo	Oak, Red
Birch, White	Oak, White
Cherry	Walnut
Hickory	

250' Wood Edgeband
Specie
Cherry
Maple, Hard

- Stock item 5 day lead-time.
- Non-stock item 15 day lead-time.

---



---

## PVC Edgeband Program

---

### Thermoplastic PVC Edgeband

- PVC edgeband rolls are 15/16" wide, 600' in length and .018" (.5mm) thick.
- Rolls of PVC edgeband are available in over 120 colors and grain patterns to match popular Conestoga finishes.
- The back side of the edgeband is coated with a bonding agent for superior adhesion when used with hot melt glues or solvent-based adhesives.
- PVC edgebands are impact resistant and perform well with cutting tools.
- The PVC edgebands listed provide a close match in appearance to the specie and finish referenced, however, due to color variations in wood substrates we cannot guarantee a perfect match. Some edgebands contain a slight texture and are identified with an asterisk in the chart. Edgeband finishes with two asteriks are 1mm thick and have a slight texture.
- Conestoga is not liable for product delamination or adhesion failure due to improper surface preparation, adhesive selection or installation technique.
- Full rolls only, partial rolls are not available through this program.
- Lead-time is 4 days, expedites not available.

Since Conestoga offers thousands of specie, finish and glaze combinations, customers may have a need for an edgeband not listed in our standard offering. In this case, Conestoga will attempt to work with our suppliers to see if an existing match can be identified. Since a sample chip of the specie/finish must be produced and shipped to the supplier, there will be a fixed charge of for this exercise, regardless if a match is found or not.

For a complete list of our current PVC Edgeband offering, please refer to the PVC Edgeband guide on the Customer Business Portal or Con-Nex, our online ordering program.

## 3D Panels

---

3D Panels are a functional way to create built-in appearances, commonly used as refrigerator end panels, at the end of cabinet runs, a bridge above or beneath wall cabinets, and as island ends. All three panel models include inner supports to prevent panels bowing or cupping. 3D Panels up to 96" are made from 3/4" thick composite core plywood. Panels above 96" will be either composite core plywood or veneer core plywood. Species available are Plain Sliced Cherry, Hard Maple, Raw MDF, Rift Cut White Oak and Walnut.

### Sizing

- Custom sizing is available to the nearest 1/16" in width, depth and height within program parameters.
- Minimum height for all models is 24", maximum standard height is 96" with vertical grain, maximum height for MDF is 96". Taller MDF heights available, but must be quoted through Special Designs. Additional lead-time required.

### Order Placement

- When placing order for any of the 3D Panel models, include the following dimensions:
  - ◆ Width of front panel (B side and/or D side).
  - ◆ Depth of exterior/exposed side panel (A side and/or C side).
  - ◆ Height of exterior/exposed side panel ( A side and/or C side).
  - ◆ Vertical or horizontal grain direction.

### Program Features

- Specify vertical or horizontal grain. (maximum size perimeters vary by grain direction).
- Finish options – available unfinished or finished in all published specie/finish selections except Distressing.

- Internal supports in 3-D Panel ends and backs are positioned 1" in from edges to fit over cleats mounted to the floor, wall and/or ceiling.
- Lead-time is 10 business days unfinished. Add 5 to 6 days for finishing.
- Expedites are not available.



### 3D Panels (continued)

11

Specialty Products

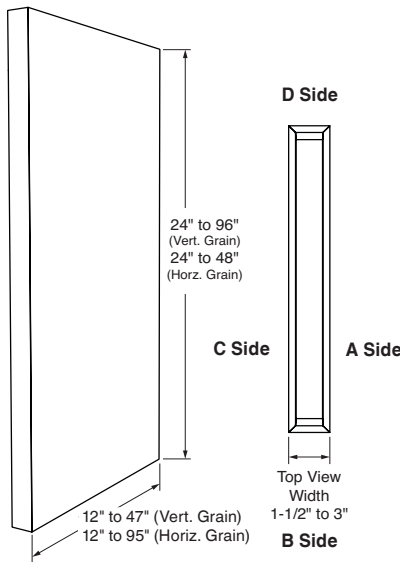

#### Box Panel

- Primarily used as island ends when both the front and back edges are exposed.
- Both ends of the Box Panel will be equal in width and height (B and D sides).
- Both side panels of the Box Panel will be equal in depth and height (A and C sides).
- Width range of front and back panels: 1-1/2" to 3" (B and D sides).
- Depth range of side panels: 12" to 47" (vertical grain). Horizontal grain depth range is 12" to 95" (A and C sides).
- Height range of side panels: 24" to 96" (vertical grain), 96" MDF. Veneered panels available 96-1/16" to 120" – additional lead-time required. Horizontal grain height range 24" to 48".

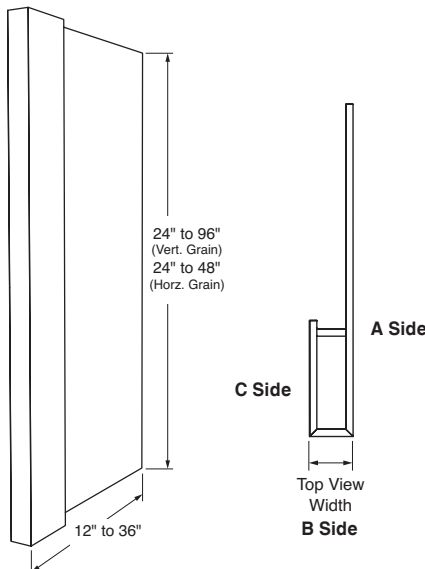

#### J-Panel

- Typically mounted against wall as base and refrigerator cabinet ends. Unfinished back edge must butt against a wall.
- The interior leg of the J-Panel (C side) is fixed at 8" depth, regardless of overall exterior panel depth.
- Width range of front panels 1-1/2" to 3" (B side).
- Depth range of side panel: 12" to 36" (A side).
- Height range of side panel: 24" to 96" (vertical grain), 96" MDF. Veneered panels available 96-1/16" to 120" – additional lead-time required. Horizontal grain height range 24" to 48".

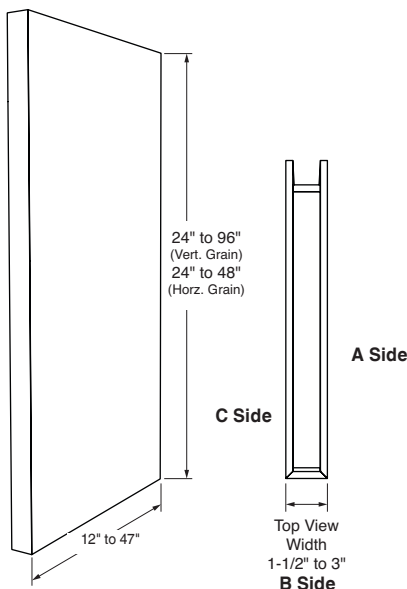

#### U-Panel

- Primarily used against wall, base and refrigerator ends as well as a bridge above or beneath wall cabinets to create a built in appearance. Unfinished back edges must butt against a wall.
- Both side panels of the U-Panel will be equal in depth and height (A and C sides).
- Width range of front panels 1-1/2" to 3" (B side).
- Depth range of side panel: 12" to 47" (A and C sides).
- Height range of side panels: 24" to 96" (vertical grain), 96" MDF. Veneered panels available 96-1/16" to 120" – additional lead-time required. Horizontal grain height range 24" to 48".

## Blum COMPACT BLUMOTION Hinge Program

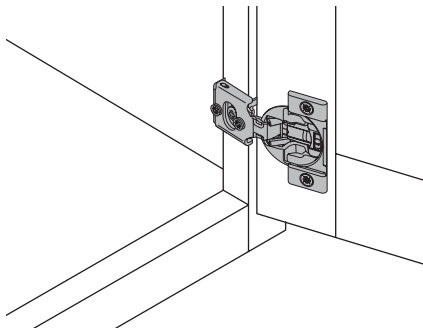

1/2" Overlay Hinge  
COMPACT BLUMOTION 38N  
105° opening angle

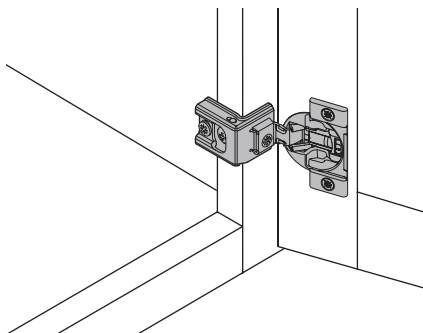

1-1/4" and 1-3/8" Overlay Hinge  
COMPACT BLUMOTION 39C  
110° opening angle

### Blum Hinges with Integrated Soft Close

- One-piece steel, concealed, self closing hinges designed for use with 3/4" thick front frames.
- Available for 1/2", 1-1/4" and 1-3/8" overlays.
- Soft close feature is integrated in the hinge cup itself.
- Soft close function can be easily deactivated with a switch on individual hinges as needed based on the door size and weight.
- Hinges packed in pairs with mounting screws.
- All hinges feature side, height, and depth adjustment for fine tuning door spacing with wraparound face frame mounting for ease of installation.
- All hinges require Pattern A – Cup Only concealed hinge boring.
- COMPACT BLUMOTION hinges carry a limited lifetime warranty.
- Lead-time is 5 days.

#### COMPACT w/Integrated BLUMOTION

Part No.	Overlay
2100150A	1/2"
2100151A	1-1/4"
2100152A	1-3/8"

#### Integrated BLUMOTION Bulk Pack (50 hinges)

Part No.	Overlay
2100153A	1/2"
2100154A	1-1/4"
2100155A	1-3/8"

## Blum Frameless Cabinetry Hinge Program

- Hinge and in-line mounting plate systems for standard, specialty and angled frameless cabinets.
- Soft close feature is integrated in the hinge cup itself unless otherwise noted.
- Soft close function can be easily deactivated with a switch on individual hinges as needed based on the door size and weight.
- Hinges packed in pairs with mounting plates and instructions.
- No screws required for hinge or mounting plate installation unless otherwise noted. Most hinges use cam style insert plugs.
- In-line mounting plates utilize 32mm system holes and are concealed behind the hinge arm when installed for a clean interior appearance.
- Hinge and mounting plate feature side to side, height and depth adjustment for fine tuning of door spacing.
- Hinges require Pattern B with Insert Holes concealed hinge boring unless otherwise noted.
- Blum hinges carry a limited lifetime warranty.
- Lead-time is 5 days.

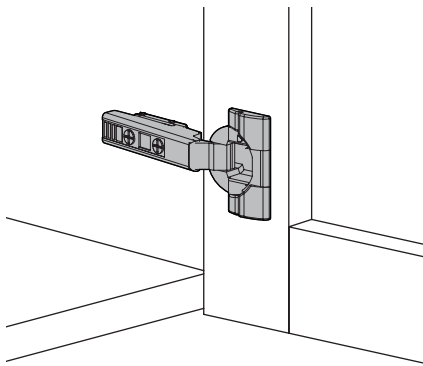

CLIP top BLUMOTION 110° hinge  
EXPANDO in-line mounting plate

### Blum INSERTA 110° Hinges

- Hinge and in-line mounting plate system for standard frameless wall, base and tall cabinetry. Will not work in angle or specialty frameless cabinetry.
- 110° opening angle.
- Part number: 2103574A.

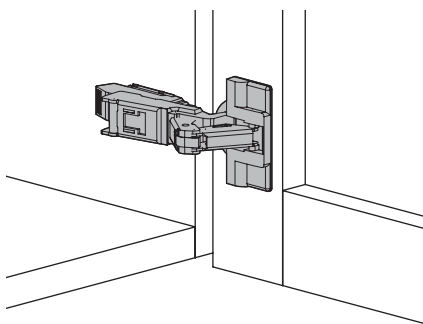

CLIP top 170° corner hinge  
EXPANDO in-line mounting plate

### Blum INSERTA 170° Corner Hinges

- Provides full access to corner cabinet interiors.
- 170° opening angle.
- Does not include soft close feature.
- INSERTA feature is not available on mounting plate. Kit includes installation screws.
- Part number: 2103575A.

**Blum Frameless Cabinetry Hinge Program (continued)**

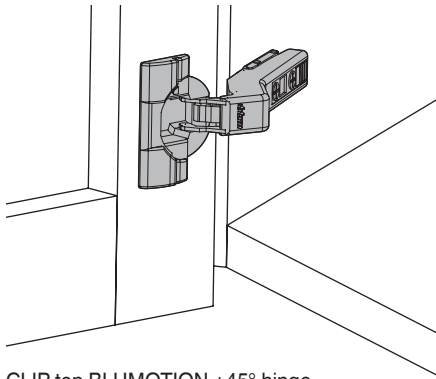

CLIP top BLUMOTION +45° hinge  
EXPANDO in-line mounting plate

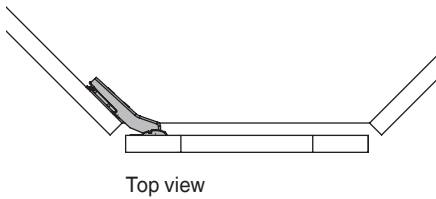

Top view

**Blum INSERTA Positive +45° Angle Hinge**

- Hinge and in-line mounting plate system for frameless diagonal corner or any angle cabinet with a 45° front.
- 110° opening angle.
- Part number: 2103581A.

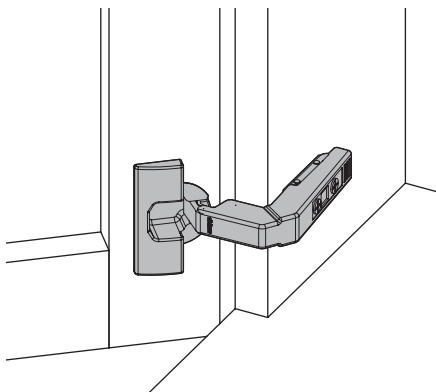

CLIP top 95° Overlay Blind Corner hinge  
EXPANDO in-line mounting plate

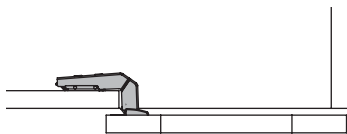

Top view

**Blum INSERTA 95° Overlay Blind Corner Hinge**

- Hinge and in-line mounting plate system for wall or base blind corner cabinets.
- 95° opening angle.
- Part number: 2103582A.

## Blum Frameless Cabinetry Hinge Program (continued)

11

Specialty Products

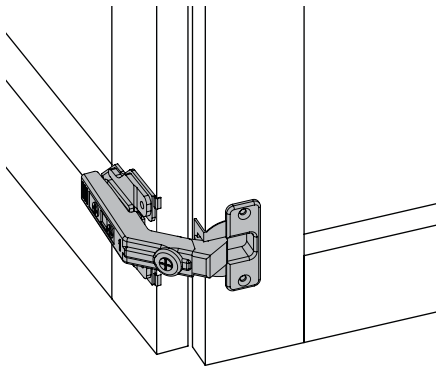

CLIP top 60° Bi-Fold hinge  
Frame adaptor mounting plate

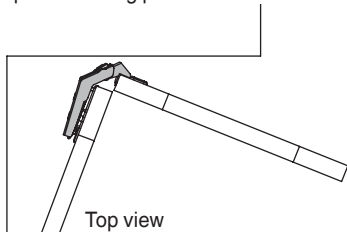

### Blum 60° Bi-Fold Door Hinge

- Hinge and edge style mounting plate to join two doors in a bi-fold application.
- INSERTA installation feature is not available on hinge or mounting plates. Kit includes installation screws.
- Use with an 170° corner hinge on adjacent door (part number 2103575A).
- Does not include soft close feature.
- Requires Bi-Fold Hinge Bore without Insert Holes – See Section 7.
- 60° opening angle.
- Part number: 2103583A.

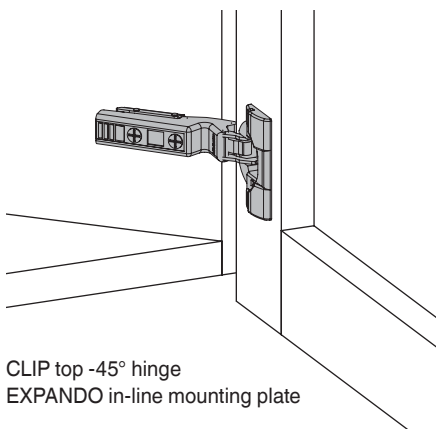

CLIP top -45° hinge  
EXPANDO in-line mounting plate

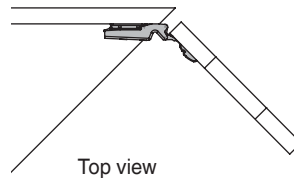

### Blum INSERTA Negative -45° Hinge

- Hinge and in-line mounting plate system for frameless angle cabinets or cabinet hinging on the opposite side of a 45°.
- 110° opening angle.
- Part number: 2103584A.

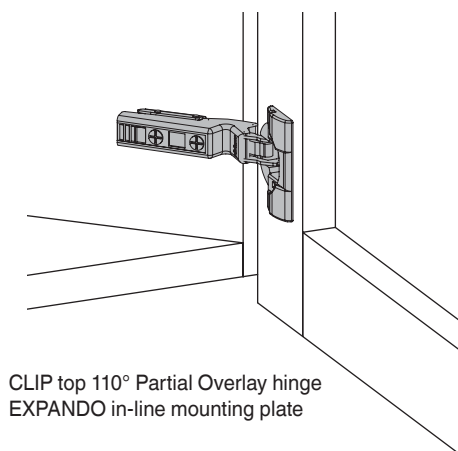

CLIP top 110° Partial Overlay hinge  
EXPANDO in-line mounting plate

### Blum INSERTA 110° Partial Overlay Hinge

- Hinge and in-line mounting plate system for frameless applications where there is a center partition.
- 110° opening angle.
- Part number: 2103675A.

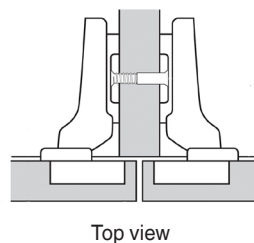

## Blum AVENTOS Door Lift System Hardware

- Blum's AVENTOS Door Lift Systems are available for hinge upward applications.
- AVENTOS HK models provide all the necessary hardware to install lift up door access for wall and tall cabinets. AVENTOS HK-XS models utilize conventional door hinges.
- Kits are designed to accommodate different door design types, weights and overlay options as well as for framed or frameless cabinet construction.
- All AVENTOS mechanisms have an integrated BLUMOTION soft close feature and include installation instructions and screws.

To determine which AVENTOS Lift System is suited for your particular application, two reference sources are available:

- A file containing our AVENTOS Lift System Calculator is provided on Conestoga's Customer Business Portal under the Marketing Resources tab. Use this tool to calculate the weight of your door and select the appropriate lift kit for your application.
- Using the charts which correspond to the different AVENTOS models below, determine the weight of the door then calculate the Blum Power Factor required to adequately lift the door as follows:  
**Door Weight + (Handle/Pull Weight X 2) = Subtotal X Door Height = Power Factor**  
**Specie and Door Weight reference chart applies to both HK-XS and HK lift systems**

Specie & Door Design Weight (approx. weight of 1 sq. ft. 3/4" thick door)				
Specie (all grades)	Slab Design	TW-series Design	CRP-series Design	Frame Only*
Alder	1.6 lb.	1.2 lb.	1.5 lb.	1.0 lb.
Birch (Red, White)	2.8 lb.	2.1 lb.	2.6 lb.	1.7 lb.
Cherry	2.5 lb.	1.9 lb.	2.3 lb.	1.5 lb.
Hickory	3.2 lb.	2.4 lb.	3.0 lb.	2.0 lb.
Maple (Hard, Soft)	2.9 lb.	2.1 lb.	2.7 lb.	1.8 lb.
MDF	3.8 lb.	3.0 lb.	3.6 lb.	2.7 lb.
Pine	1.6 lb.	1.5 lb.	1.9 lb.	1.3 lb.
Oak, Red & White	3.1 lb.	2.1 lb.	2.9 lb.	1.9 lb.
Walnut	2.6 lb.	2.0 lb.	2.5 lb.	1.6 lb.
Allure DLV	2.6 lb.	1.8 lb.	NA	1.5 lb.
High Gloss (Slab)	3.8 lb.	NA	NA	NA
Intrigue TTS	2.6 lb.	1.9 lb.	NA	1.6 lb.
Super Matte (Slab)	3.8 lb.	NA	NA	NA
Strata TTS	2.6 lb.	1.9 lb.	NA	1.6 lb.
Vogue TTS	2.6 lb.	1.9 lb.	NA	1.6 lb.

\*Does not include weight of glass.

**Blum AVENTOS Door Lift System Hardware (continued)**

11

Specialty Products

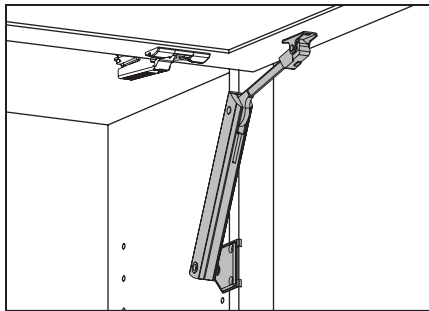

**Blum AVENTOS HK-XS**

- XS-Series utilize conventional hinges (not included).
- Units are symmetrical and can be installed on one or both sides.
- Cabinet heights from 9-1/2" to 24" and cabinet widths up to 72".
- Minimum interior depth required is 5".
- Four AVENTOS kits provide all the necessary hardware designed for different weight doors for both framed and frameless cabinet construction.

**AVENTOS HK-XS Reference Chart**

Power Factor (1 Lift)	Power Factor (2 Lifts)	Door Weight	Part No.
<b>Framed Cabinet Construction</b>			
17 – 84	34 – 124	Light	2103578A
113 – 180	225 – 336	Heavy	2103580A
<b>Frameless Cabinet Construction</b>			
17 – 84	34 – 124	Light	2103577A
113 – 180	225 – 336	Heavy	2103579A

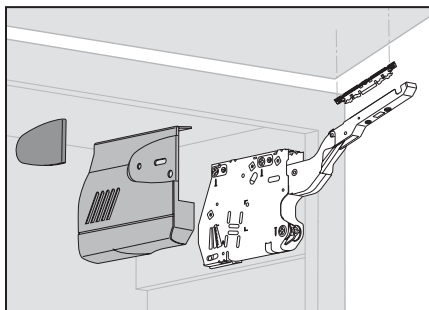

**Blum AVENTOS HK**

- Simple, virtually tool free assembly and easy adjustment.
- Specifically designed for frameless wall and tall utility applications.
- Cabinet heights from 11-13/16" to 24" and cabinet widths to 72".
- Minimum cabinet interior depth required is 8-1/4".

**AVENTOS HK Reference Chart**

Power Factor	HK Kit Series	Part No.
43 – 99	2300	2100350A
100 – 174	2500	2100351A
175 – 349	2700	2100352A
350 – 792	2900	2100353A

**AVENTOS Accessory Items**

Description	Part No.
Mounting Hardware Set	2100354A
100° Restriction Clip	2100355A
75° Restriction Clip	2100356A

## Entry Level Range Hoods

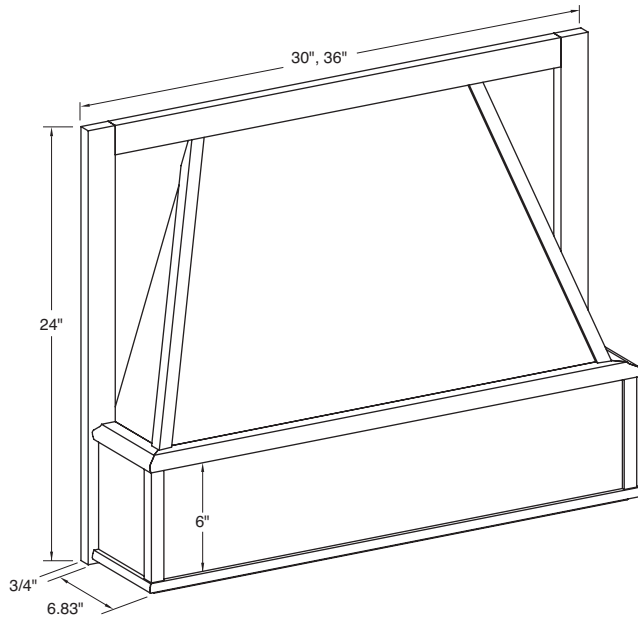

### Select Range Hood

- Hood must be secured to adjacent cabinets.
- Manufactured from solid wood and wood veneers.
- Includes 24 gauge silver metallic liner.
- Liner accommodates the following Broan ventilators: 250CFM - RHVBF300SS  
400CFM - RHVB400SS  
Contact Omega National Products:  
(800) 533-8809.
- Lead-time 10 days unfinished, add 5-6 days for finishing.
- Available in Alder, Cherry, Hard Maple and Red Oak.
- **Custom sizes not available.**

Height	Available Sizes	
24"	30x24	36x24

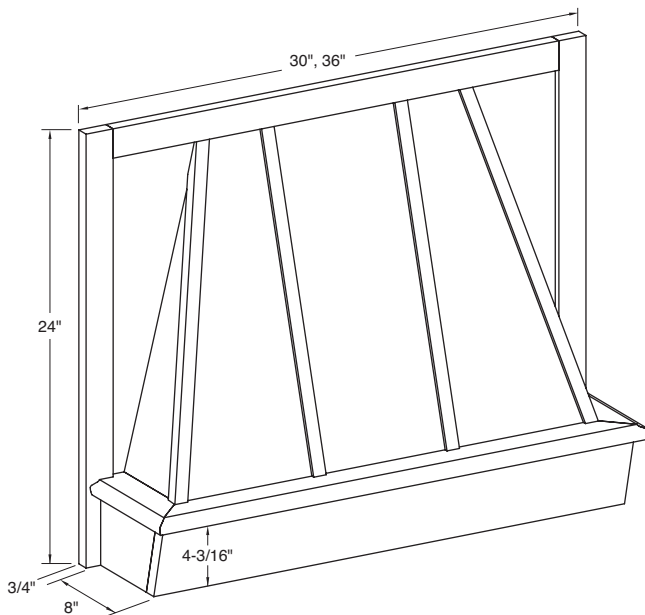

### Batten Select Range Hood

- Hood must be secured to adjacent cabinets.
- Manufactured from solid wood and wood veneers.
- Includes 24 gauge silver metallic liner.
- Liner accommodates the following Broan ventilators: 250CFM - RHVBF300SS  
400CFM - RHVB400SS  
Contact Omega National Products:  
(800) 533-8809.
- Lead-time 10 days unfinished, add 5-6 days for finishing.
- Available in Alder, Cherry, Hard Maple and Red Oak.
- **Custom sizes not available.**

Height	Available Sizes	
24"	30x24	36x24



## Range Hoods

### Straight Farmhouse Hood

- Shiplap wall-mounted hood with galvanized steel mounting bracket for easy installation.
- Manufactured from solid wood and veneer core plywood.
- Moulding at top of hood is attached with 6 screws allowing for easy removal if the top needs to be trimmed to height.
- Shiplap spaced at 6" intervals.
- Solid wood arched valance.
- 1-3/8" wood corner mouldings are shipped loose to allow for trimming to desired height.
- Includes silver metallic powder-coated liner.
- Liner accommodates the following Broan ventilators:
  - 250 CFM - RHVBF300SS
  - 400 CFM - RHVB400SS
  - 600 CFM - RHVB600SSV
- Contact Omega National Products: (800) 533-8809.
- Lead-time 15 days unfinished, add 5-6 days for finishing.
- Available in Alder, Cherry, Hard Maple, PGHM Hybrid\* and Red Oak.
- **Custom sizes not available.**

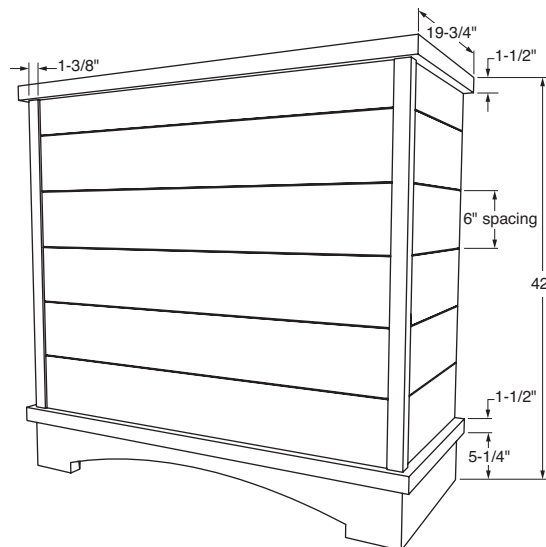

Height	Available Sizes		
42"	36x42	42x42	48x42

\*MDF w/Maple mouldings.

## Range Hoods (continued)

### Tapered Farmhouse Hood w/Detached Chimney

- Shiplap wall-mounted hood with galvanized steel mounting bracket for easy installation.
- Manufactured from solid wood and veneer core plywood.
- Chimney and base ship in separate cartons. Moulding at top of chimney is attached with 4 screws allowing for easy removal if the top needs to be trimmed to height. Mouldings on the side of the chimney are shipped loose to allow for trimming if needed.
- 6" hardwood base.
- Shiplap spaced at 6" intervals.
- 1-3/8" wood corner mouldings attached.
- Includes silver metallic powder-coated liner.
- Liner accommodates the following Broan ventilators:
  - 250 CFM - RHVBF300SS
  - 400 CFM - RHVB400SS
  - 600 CFM - RHVB600SSV
- Contact Omega National Products: (800) 533-8809.
- Lead-time 15 days unfinished, add 5-6 days for finishing.
- Available in Alder, Cherry, Hard Maple, PGHM Hybrid\* and Red Oak.
- **Custom sizes not available.**

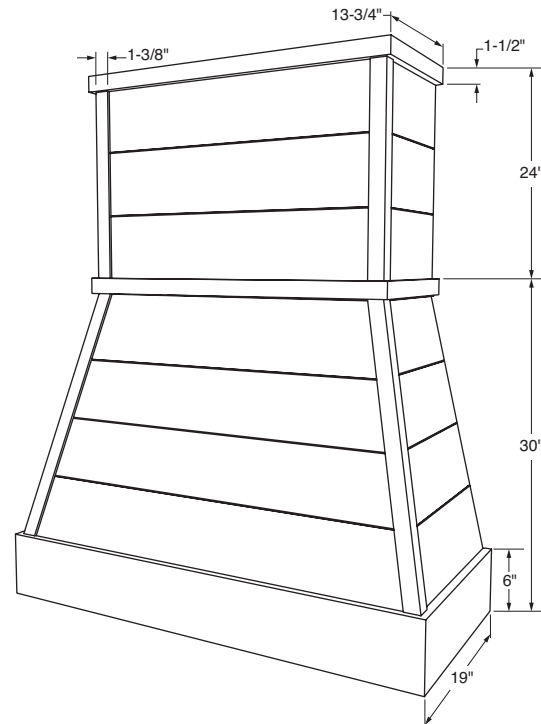

Height	Available Sizes			
30"	30x30	36x30	42x30	48x30

\*MDF w/Maple mouldings.

## Range Hoods (continued)

11

Specialty Products

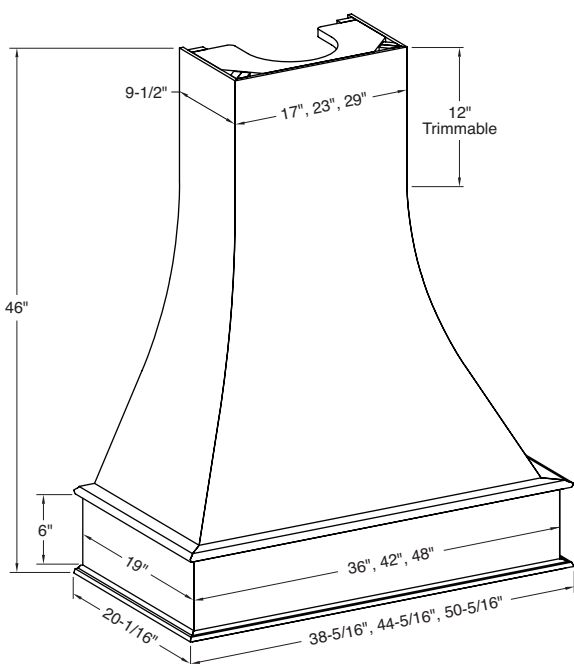

### Artisan Range Hood

- Complete turnkey solution with patented hanging cleat for quick and easy installation.
- Manufactured from solid wood and wood veneers.
- Up to 12" may be trimmed from the top of the chimney.
- Includes silver metallic powder-coated liner.
- Liner accommodates the following Broan ventilators:
  - 250 CFM - RHVBF300SS
  - 400 CFM - RHVB400SS
  - 600 CFM - RHVB600SSV
- Contact Omega National Products: (800) 533-8809.
- Lead-time 15 days unfinished, add 5-6 days for finishing.
- Available in Cherry, Hard Maple, PGHM Hybrid\* and Red Oak.
- **Custom sizes not available.**

Height	Available Sizes			
46"	30x46	36x46	42x46	48x46

\*MDF w/Maple mouldings.

## Stanisci Design Range Hoods

Stanisci Design is the leading manufacturer of wood range hoods for the custom kitchen industry. This program allows for convenient ordering of custom range hoods and ventilation units. Conestoga's published offering includes several popular hood designs with panel raise and bead options. Both plywood and raised panel hoods are available in a wide variety of heights and widths.

### Program Details

- Range hoods are available unfinished or finished;
- Most prefinished hoods will ship from Conestoga's Kenly, N.C. facility.
- Custom species include African Mahogany, Hickory and Rustic Knotty Alder. Contact Special

Designs for other specie availability.

- Custom sizes and designs are available. Contact Special Designs for a quote.

### Examples of custom designs:

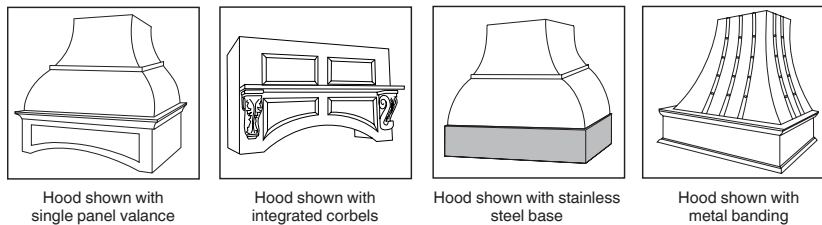

- Liners are not included with hood unless otherwise noted. Stainless steel ventilation units and liners are available from Stanisci Design with discounted Conestoga program pricing.
- Recommended ventilator: Stainless steel units from 300 to 1500 CFM are available through Stanisci Design (248) 572-6880.
- Stanisci hoods are available in catalog format, compatible with 20/20 Design software. Contact your Sales Representative for information.
- Value line ventilation systems are also available for Stanisci Design range hoods: silver metallic powder coat finish, 390 CFM multi-blower with two 40w lights (no discount available).

**PLEASE NOTE: All Stanisci Range Hoods should be mounted no closer than 30" above cook tops, although some cook tops require additional clearance. Please check local building codes and appliance specifications.**

## Removable Options

### Removable Applied Panel

- Available on I-Series hood design only.
- Allows for easy installation and access for Building Inspectors.
- Panel features applied moulding for finished look after installation.
- Specify "Removable Panel Option", Upcharge applies.

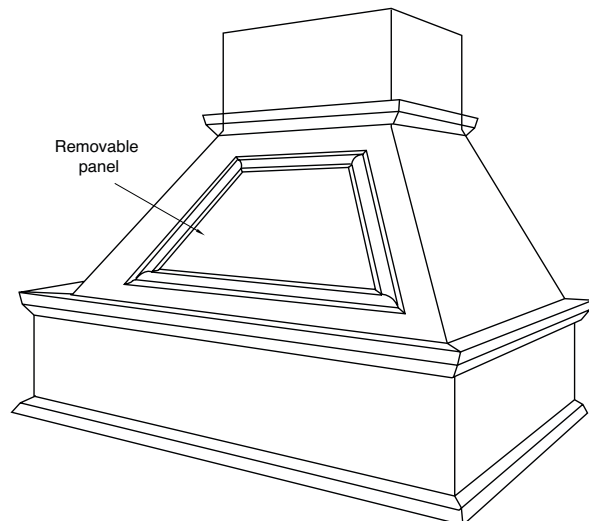

## Stanisci Design Range Hoods (continued)

### Removable Front

- Available on P and Z200 Series hoods at no additional charge.
- With this option, the entire front fascia lifts straight up for easy removal. When installed, the hood face is secured in place with concealed clips.
- If this option is selected, the depth of the P and Z200 box will be modified to 16" deep. Overall hood depth will remain the same as standard depth.
- No additional lead-time required.
- When ordering, specify the hood design then "Removable Option".

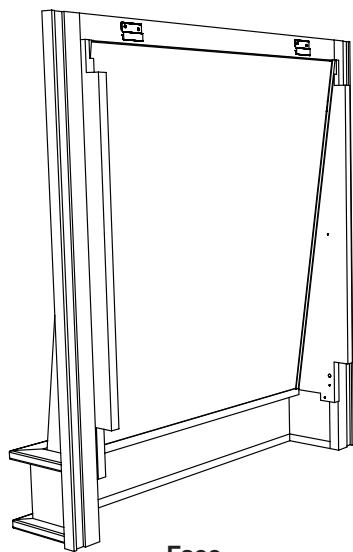

Face

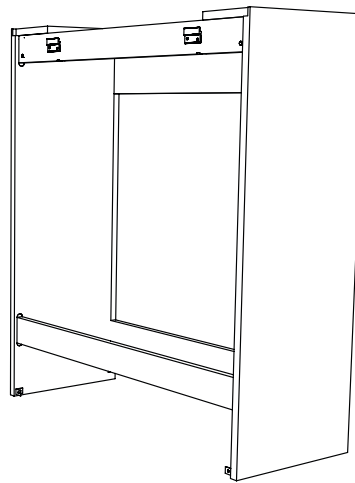

Box

### Removable Top

- Available on the CHW, CHWB, E, FX2HW, FX2PL, G, GRA, S, T and TRA Series hoods at no additional charge.
- This option allows the base of the hood to be installed separately, followed by the ventilation. After ventilation hookup has been completed, the top portion of the hood can lower into place and be secured to the base.
- No additional lead-time required.
- When ordering, specify the hood design then "Removable Option".

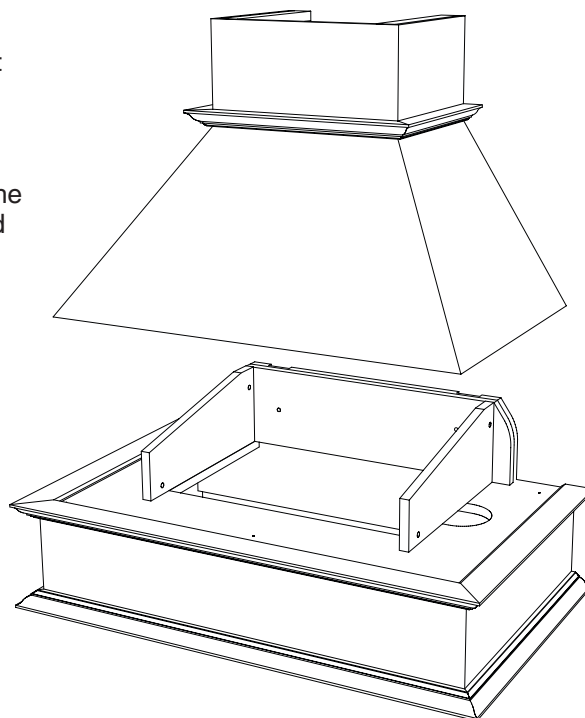

## Stanisci Design Range Hoods (continued)

---

### Optional Moulding Packages

- Several hoods are available with a choice of Classic, Simple or Basic moulding packages. See illustrations below for examples of differences between the three moulding profiles.
- Classic package is a more traditional style moulding. Simple and Basic packages are made for contemporary/transitional kitchens.
- Moulding packages have no effect on pricing, lead-time or overall dimensions.
- Moulding packages available on all Stanisci hoods except B, BX, BXB, CHW, CHWB, E3, FX, FXBPUP, FX2HW, M, VCHM-AV, VCHM-SV and VCHM-VRS hoods.
- Moulding packages below are available for E, FX2PL, G, GRA, H2, I, S, SRA, T and TRA hoods (P and Z200 available in Basic package only).
- When ordering a range hood specify the desired moulding package.



Classic Package



Simple Package



Basic Package

### Antiquing, Distressing and Wear Sanding

To allow our customers to purchase prefinished Stanisci range hoods with the same overall appearance of their doors, Conestoga offers a modified version of our Antiquing, Distressing and Wear Sanding Options on the solid wood portions of Stanisci hoods.

- These treatment options available with Stanisci-brand range hoods only.
- Not available on Paint Grade Hard Maple Hybrid specie hoods.
- Availability of these options varies by hood design.

## Stanisci Design Range Hoods (continued)

### VCHIM Series Hood – Straight Valance

- Stylish straight valance complements traditional or contemporary designs.
- Designed to fit up to a 9 foot ceiling.
- Plywood chimney and upper. Solid wood apron.
- 17-1/4" chimney can be trimmed to desired height and is shipped unattached.
- Lead-time 5 days unfinished, add 7 days for finishing.
- Fixed panel standard. Removable top not available.
- Ventilators available through Stanisci Design.
- Available in Alder, Cherry, Hard Maple and Red Oak.
- **Custom sizes not available.**

Height	VCHIM-SV Series Part Number			
42"	SV-30x42	SV-36x42	SV-42x42	SV-48x42

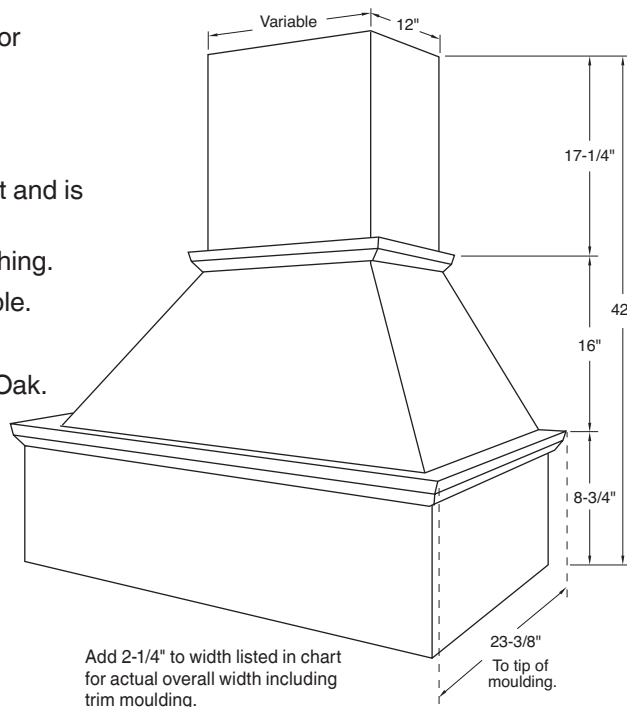

### VCHIM Series Hood – Arched Valance

- Stylish arched valance complements traditional and transitional designs.
- Arched valance has Regular bead, G-Cove Raise - no options.
- Designed to fit up to a 9 foot ceiling.
- 17-1/4" plywood chimney can be trimmed to desired height and is shipped unattached.
- Lead-time 5 days unfinished, add 7 days for finishing.
- Fixed panel standard. Removable top not available.
- Ventilators available through Stanisci Design.
- Available in Alder, Cherry, Hard Maple and Red Oak.
- **Custom sizes not available.**

Height	VCHIM-AV Series Part Number			
42"	AV-30x42	AV-36x42	AV-42x42	AV-48x42

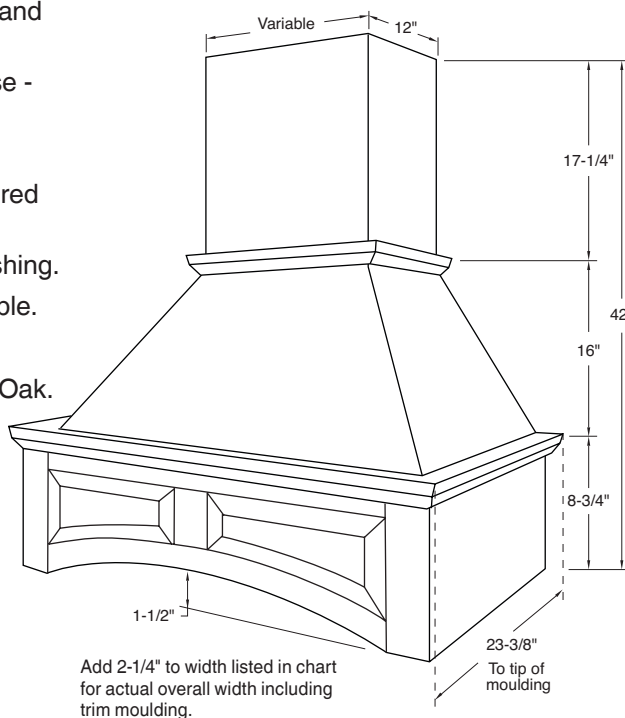

## Stanisci Design Range Hoods (continued)

### VCHIM Series Hood – Two Panel Straight Valance

- Stylish straight valance complements transitional or traditional designs.
- Two panel straight valance has Square bead, flat panel - no options.
- Designed to fit up to a 9 foot ceiling.
- 17-1/4" plywood chimney can be trimmed to desired height and is shipped unattached.
- Lead-time 5 days unfinished, add 7 days for finishing.
- Fixed panel standard. Removable top not available.
- Ventilators available through Stanisci Design.
- Available in Alder, Cherry, Hard Maple and Red Oak.
- **Custom sizes not available.**

Height	VCHIM-VRS Series Part Number			
42"	VRS-30x42	VRS-36x42	VRS-42x42	VRS-48x42

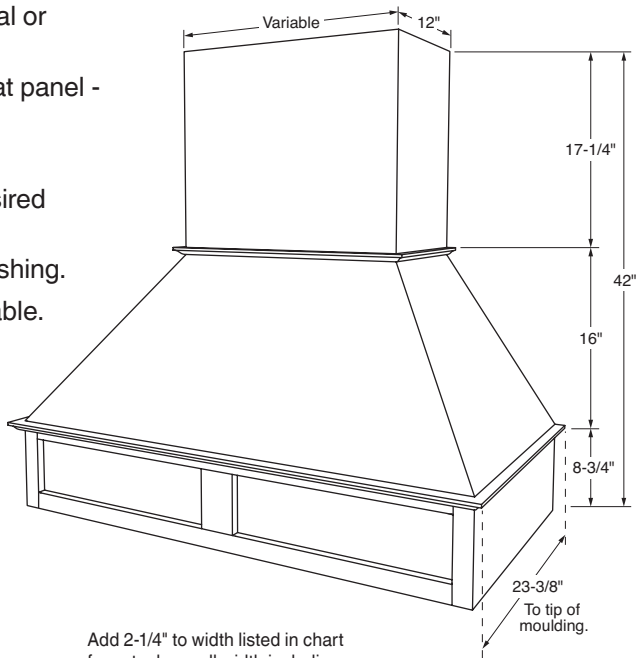

Add 2-1/4" to width listed in chart for actual overall width including trim moulding.



## Stanisci Design Range Hoods (continued)

### BX – Standard Hood

- BX-Series is a contemporary or transitional hood.
- Horizontal grain only.
- Lead-time 10 days unfinished, add 7 days for finishing.
- Fixed panel only.
- Moulding package not available.
- Available in Alder, Cherry, Hard Maple, PGHM Hybrid, Red Oak, Walnut and Quarter Sawn White Oak.
- **Custom sizes available through Special Designs.**

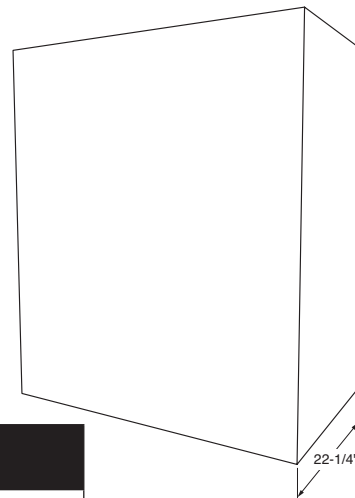

Height	BX-Series Part Number					
24"	BX-30x24	BX-36x24	BX-42x24	BX-48x24	BX-54x24	BX-60x24
30"	BX-30x30	BX-36x30	BX-42x30	BX-48x30	BX-54x30	BX-60x30
36"	BX-30x36	BX-36x36	BX-42x36	BX-48x36	BX-54x36	BX-60x36
42"	BX-30x42	BX-36x42	BX-42x42	BX-48x52	BX-54x42	BX-60x42

### BXB – Horizontal Beading Hood

- BX-Series is a shiplap hood.
- Horizontal grain only with shiplap style beading.
- Width face of shiplap moulding varies by hood height.
- Lead-time 10 days unfinished, add 7 days for finishing.
- Fixed panel only.
- Moulding package not available.
- Available in Alder, Cherry, Hard Maple, PGHM Hybrid, Red Oak, Walnut and Quarter Sawn White Oak.
- **Custom sizes available through Special Designs.**

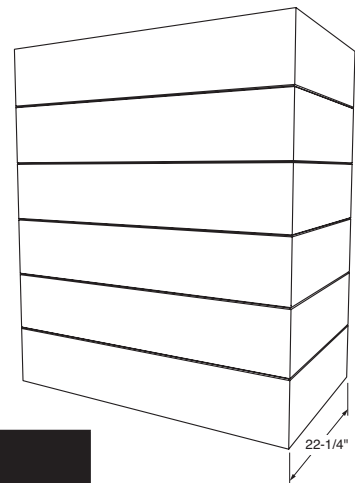

Height	BXB-Series Part Number					
24"	BXB-30x24	BXB-36x24	BXB-42x24	BXB-48x24	BXB-54x24	BXB-60x24
30"	BXB-30x30	BXB-36x30	BXB-42x30	BXB-48x30	BXB-54x30	BXB-60x30
36"	BXB-30x36	BXB-36x36	BXB-42x36	BXB-48x36	BXB-54x36	BXB-60x36
42"	BXB-30x42	BXB-36x42	BXB-42x42	BXB-48x52	BXB-54x42	BXB-60x42

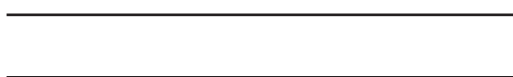

## Stanisci Design Range Hoods (continued)

### CHW – Standard Hood

- CHW-Series is a contemporary or transitional hood.
- Horizontal grain panel and valance only.
- 6" hardwood valance in matching specie only.
- Lead-time 10 days unfinished, add 7 days for finishing.
- Fixed panel standard. Removable top optional.
- Moulding package not available.
- Available in Alder, Cherry, Hard Maple, PGHM Hybrid, Red Oak, Walnut and Quarter Sawn White Oak.
- **Custom sizes available through Special Designs.**

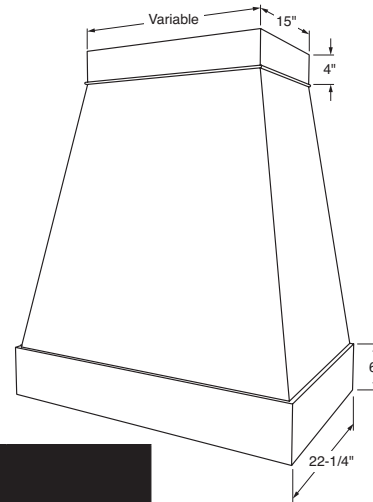

Height	CHW-Series Part Number					
24"	CHW-30x24	CHW-36x24	CHW-42x24	CHW-48x24	CHW-54x24	CHW-60x24
30"	CHW-30x30	CHW-36x30	CHW-42x30	CHW-48x30	CHW-54x30	CHW-60x30
36"	CHW-30x36	CHW-36x36	CHW-42x36	CHW-48x36	CHW-54x36	CHW-60x36
48"	CHW-30x48	CHW-36x48	CHW-42x48	CHW-48x48	CHW-54x48	CHW-60x48
54"	CHW-30x54	CHW-36x54	CHW-42x54	CHW-48x54	CHW-54x54	CHW-60x54

### CHWB – Horizontal Beading

- CHWB-Series is a shiplap style hood.
- Horizontal grain only with shiplap style beading.
- 6" hardwood valance in matching specie only.
- Width face of shiplap moulding varies by hood height.
- Lead-time 10 days unfinished, add 7 days for finishing.
- Fixed panel standard. Removable top optional.
- Moulding package not available.
- Available in Alder, Cherry, Hard Maple, PGHM Hybrid, Red Oak, Walnut and Quarter Sawn White Oak.
- **Custom sizes available through Special Designs.**

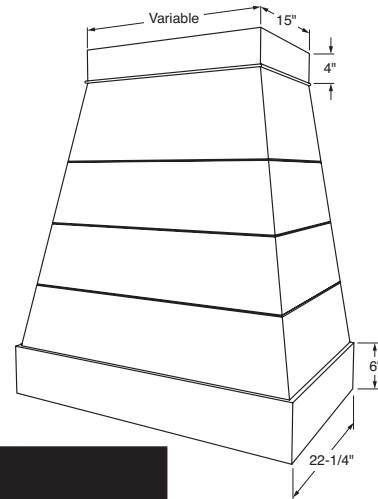

Height	CHWB-Series Part Number					
24"	CHWB-30x24	CHWB-36x24	CHWB-42x24	CHWB-48x24	CHWB-54x24	CHWB-60x24
30"	CHWB-30x30	CHWB-36x30	CHWB-42x30	CHWB-48x30	CHWB-54x30	CHWB-60x30
36"	CHWB-30x36	CHWB-36x36	CHWB-42x36	CHWB-48x36	CHWB-54x36	CHWB-60x36
48"	CHWB-30x48	CHWB-36x48	CHWB-42x48	CHWB-48x48	CHWB-54x48	CHWB-60x48
54"	CHWB-30x54	CHWB-36x54	CHWB-42x54	CHWB-48x54	CHWB-54x54	CHWB-60x54

## Stanisci Design Range Hoods (continued)

### G – Standard Hood

- G-Series is designed to best fit 8 foot ceilings.
- Removable chimney may be trimmed to desired height.
- Lead-time 10 days unfinished, add 7 days for finishing.
- Fixed panel standard. Removable top optional.
- Available in Alder, Cherry, Hard Maple, Red Oak, PGHM Hybrid, Walnut and Quarter Sawn White Oak.
- **Custom sizes available through Special Designs.**

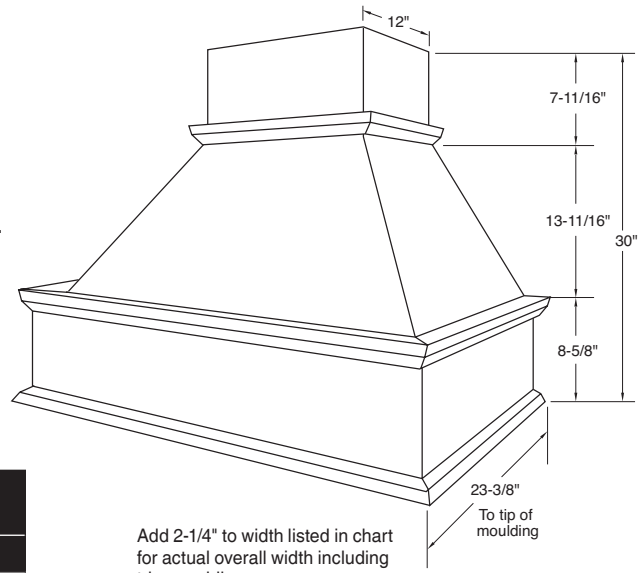

Height	G-Series Part Number				
	G-36	G-42	G-48	G-54	G-60
30"	G-36x30	G-42x30	G-48x30	G-54x30	G-60x30

### G – Raised Arch Hood

- G-Raised Arch Series is designed to best fit 8 foot ceilings.
- Profile options – Framing Bead: Regular, Elite, Ogee, Square or F-1223. Panel Raise: Slant, G-Cove, RM, M-Bead or P-057.
- Removable chimney may be trimmed to desired height.
- Lead-time 10 days unfinished, add 7 days for finishing.
- Fixed panel standard. Removable top optional.
- Available in Alder, Cherry, Hard Maple, Red Oak, PGHM Hybrid, Walnut and Quarter Sawn White Oak.
- **Custom sizes available through Special Designs.**

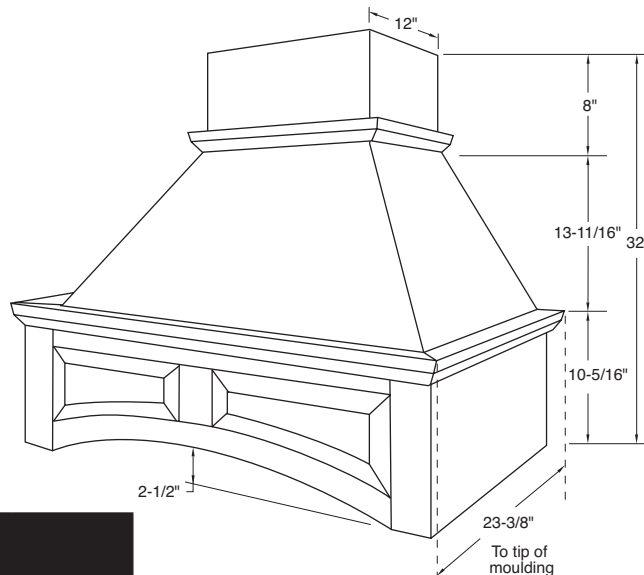

Height	GRA-Series Part Number				
	GRA-36	GRA-42	GRA-48	GRA-54	GRA-60
32"	GRA-36x32	GRA-42x32	GRA-48x32	GRA-54x32	GRA-60x32

## Stanisci Design Range Hoods (continued)

### T – Standard Hood

- T-Series is designed to best fit 9 foot ceilings and taller.
- Removable chimney may be trimmed to desired height.
- Lead-time 10 days unfinished, add 7 days for finishing.
- Fixed panel standard. Removable top optional.
- Available in Alder, Cherry, Hard Maple, Red Oak, PGHM Hybrid, Walnut and Quarter Sawn White Oak.
- **Custom sizes available through Special Designs.**

Height	T-Series Part Number				
	T-36	T-42	T-48	T-54	T-60
42"	T-36x42	T-42x42	T-48x42	T-54x42	T-60x42

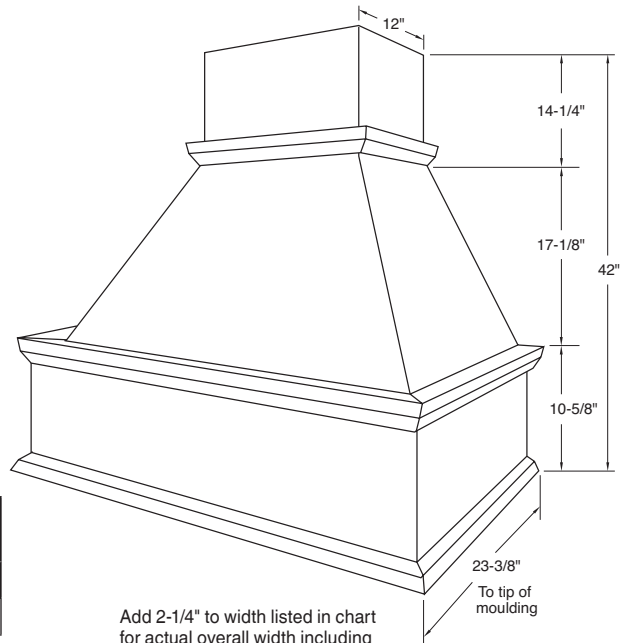

Add 2-1/4" to width listed in chart for actual overall width including trim moulding.

### T – Raised Arch Hood

- T-Raised Arch Series is designed to best fit 9 foot ceilings and taller.
- Profile options –  
Framing Bead: Regular, Elite, Ogee, Square or F-1223.  
Panel Raise: Slant, G-Cove, RM, M-Bead or P-057.
- Removable chimney may be trimmed to desired height.
- Lead-time 10 days unfinished, add 7 days for finishing.
- Fixed panel standard. Removable top optional.
- Available in Alder, Cherry, Hard Maple, Red Oak, PGHM Hybrid, Walnut and Quarter Sawn White Oak.
- **Custom sizes available through Special Designs.**

Height	TRA-Series Part Number				
	TRA-36	TRA-42	TRA-48	TRA-54	TRA-60
42"	TRA-36x42	TRA-42x42	TRA-48x42	TRA-54x42	TRA-60x42

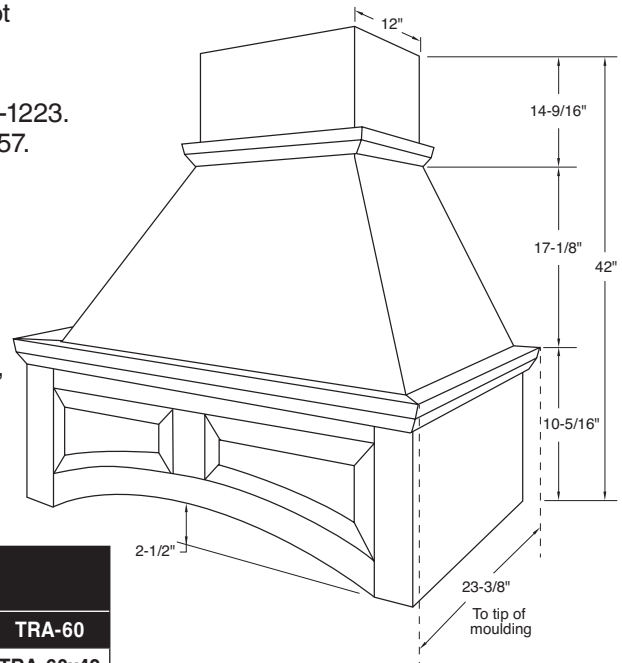

Add 2-1/4" to width listed in chart for actual overall width including trim moulding.

## Stanisci Design Range Hoods (continued)

### I – Series (Four-sided Island Hood)

- I-Series hood is designed to provide ventilation above an island range.
- Overall height must be provided when ordering I-series.
- Prefinished hoods will be finished on all 4 sides.
- Includes installation hardware.
- Lead-time 10 days unfinished, add 7 days for finishing.
- Fixed panel standard. Removable panel optional.
- Available in Alder, Cherry, Hard Maple, PGHM Hybrid, Red Oak, Walnut and Quarter Sawn White Oak.
- **Custom sizes available through Special Designs.**

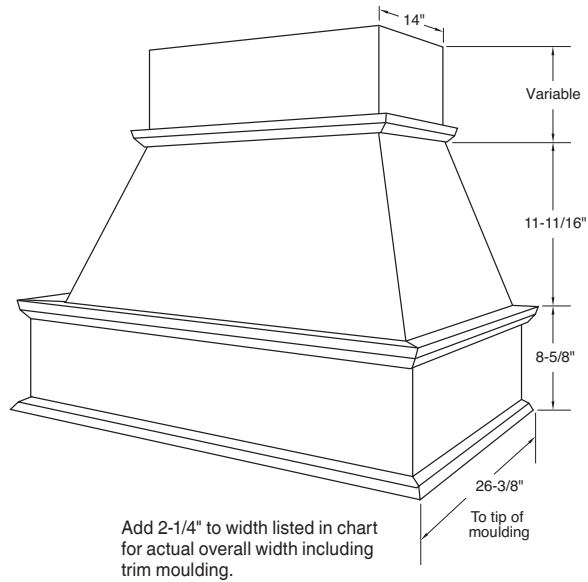

Specify Height	I-Series Part Number				
Width	I-36	I-42	I-48	I-54	I-60

### M – Series Hood

- Will accommodate corbels up to 5" wide, 10-1/2" high and 6" deep under display shelf. See the Wood Accents and Ornament pages in Section 12 or the Art for Everyday catalog on the CBP for potential corbel selections.
- Profile options –  
Framing Bead: Regular, Elite, Ogee, Square or F-1223.  
Panel Raise: Slant, G-Cove, RM, M-Bead or P-057.
- Hood includes 6-3/4" deep display shelf, shipped unattached.
- Lead-time 10 days unfinished, add 7 days for finishing.
- Removable panel only. Fixed top rail standard.
- Available in Alder, Cherry, Hard Maple, PGHM Hybrid, Red Oak, Walnut and Quarter Sawn White Oak.
- **Custom sizes available through Special Designs.**

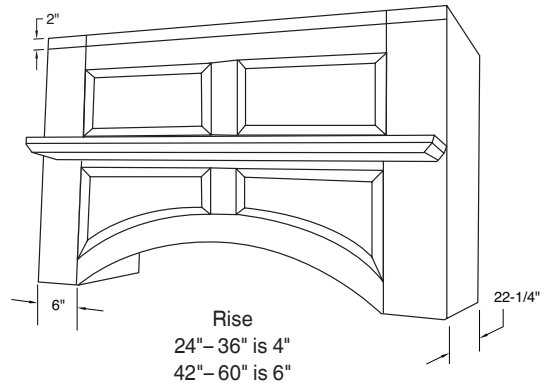

Height	M-Series Part Number					
24"	M-30x24	M-36x24	M-42x24	M-48x24	M-54x24	M-60x24
30"	M-30x30	M-36x30	M-42x30	M-48x30	M-54x30	M-60x30
36"	M-30x36	M-36x36	M-42x36	M-48x36	M-54x36	M-60x36
42"	M-30x42	M-36x42	M-42x42	M-48x42	M-54x42	M-60x42
48"	M-30x48	M-36x48	M-42x48	M-48x48	M-54x48	M-60x48

## Stanisci Design Range Hoods (continued)

### S – Raised Hood w/Display Shelf

- Profile options –  
Framing Bead: Regular, Elite, Ogee, Square or F-1223.  
Panel Raise: Slant, G-Cove, RM, M-Bead or P-057.
- Display shelf depth is 6-1/8" to tip of moulding.
- Lead-time 10 days unfinished, add 7 days for finishing.
- Removable panel only.
- Available in Alder, Cherry, Hard Maple, PGHM Hybrid, Red Oak, Walnut and Quarter Sawn White Oak.
- Custom sizes available through Special Designs.
- **Custom sizes available through Special Designs.**

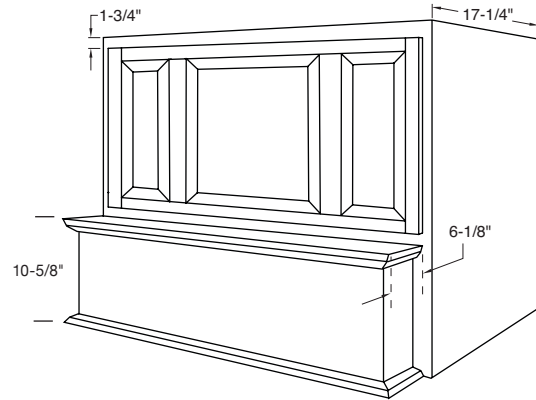

Height	S-Series					
	Part Number					
24"	S-33x24	S-39x24	S-45x24	S-51x24	S-57x24	S-63x24
30"	S-33x30	S-39x30	S-45x30	S-51x30	S-57x30	S-63x30
36"	S-33x36	S-39x36	S-45x36	S-51x36	S-57x36	S-63x36
42"	S-33x42	S-39x42	S-45x42	S-51x42	S-57x42	S-63x42

### S – Raised Arch Hood w/Display Shelf

- Profile Options –  
Framing Bead: Regular, Elite, Ogee, Square or F-1223.  
Panel Raise: Slant, G-Cove, RM, M-Bead or P-057.
- Display shelf depth is 6-1/8" deep.
- Lead-time 10 days unfinished, add 7 days for finishing.
- Removable panel only.
- Available in Alder, Cherry, Hard Maple, PGHM Hybrid, Red Oak, Walnut and Quarter Sawn White Oak.
- **Custom sizes available through Special Designs.**

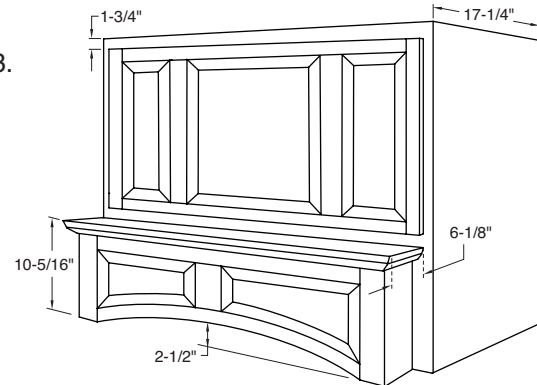

Height	SRA-Series					
	Part Number					
24"	SRA-33x24	SRA-39x24	SRA-45x24	SRA-51x24	SRA-57x24	SRA-63x24
30"	SRA-33x30	SRA-39x30	SRA-45x30	SRA-51x30	SRA-57x30	SRA-63x30
36"	SRA-33x36	SRA-39x36	SRA-45x36	SRA-51x36	SRA-57x36	SRA-63x36
42"	SRA-33x42	SRA-39x42	SRA-45x42	SRA-51x42	SRA-57x42	SRA-63x42

## Stanisci Design Range Hoods (continued)

### H2 – Series Hood w/Display Shelf

- Hearth style hood featuring incorporated display shelf.
- Profile options –  
Framing Bead: Regular, Elite, Ogee, Square or F-1223.  
Panel Raise: Slant, G-Cove, RM, M-Bead or P-057.
- Display shelf depth is 8-1/8" to tip of moulding.
- 42" and 54" wide hoods have two top panels.
- 60" and 66" wide hoods have three panels on top wainscot.
- Lead-time 10 days unfinished, add 7 days for finishing.
- Removable panel only. Fixed top rail standard.
- Available in Alder, Cherry, Hard Maple, PGHM Hybrid, Red Oak, Walnut and Quarter Sawn White Oak.
- **Custom sizes available through Special Designs.**

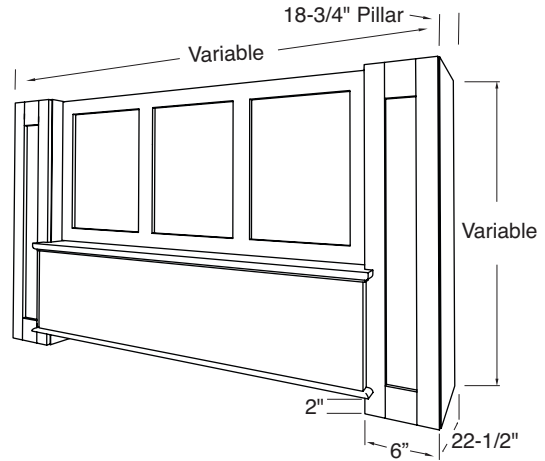

Height	H2-Series Part Number				
32"	H2-42x32	H2-48x32	H2-54x32	H2-60x32	H2-66x32
38"	H2-42x38	H2-48x38	H2-54x38	H2-60x38	H2-66x38
44"	H2-42x44	H2-48x44	H2-54x44	H2-60x44	H2-66x44

### B – Series Hood w/Display Shelf

- B-Series is designed to best fit 8 to 10 foot ceilings.
- B-Series hoods are not recommended to be cut down in the field – specify height at time of order.
- Lead-time 10 days unfinished, add 7 days for finishing.
- Fixed panel only.
- Moulding package not available.
- Available in Alder, Cherry, Hard Maple, PGHM Hybrid, Red Oak, Walnut and Quarter Sawn White Oak.
- **Custom sizes available through Special Designs.**

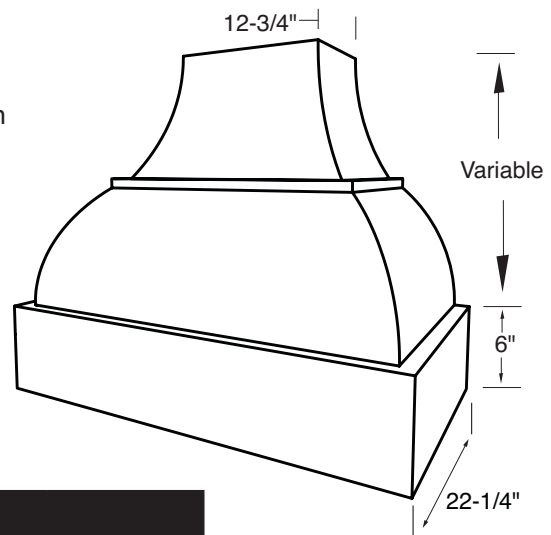

Height	B-Series Part Number				
30"	B-36x30	B-42x30	B-48x30	B-54x30	B-60x30
42"	B-36x42	B-42x42	B-48x42	B-54x42	B-60x42
48"	B-36x48	B-42x48	B-48x48	B-54x48	B-60x48

## Stanisci Design Range Hoods (continued)

### E – Standard Hood

- E-Series can be sized to fit 8 or 9 foot ceilings.
- E-Series hoods are not trimmable. Specific heights available through Special Designs.
- Lead-time 10 days unfinished, add 7 days for finishing.
- Fixed panel standard. Removable top optional.
- Available in Alder, Cherry, Hard Maple, PGHM Hybrid, Red Oak, Walnut and Quarter Sawn White Oak.
- **Custom sizes available through Special Designs.**

Height	E-Series				
	Part Number				
30"	E-36x30	E-42x30	E-48x30	E-54x30	E-60x30
42"	E-36x42	E-42x42	E-48x42	E-54x42	E-60x42
48"	E-36x48	E-42x48	E-48x48	E-54x48	E-60x48

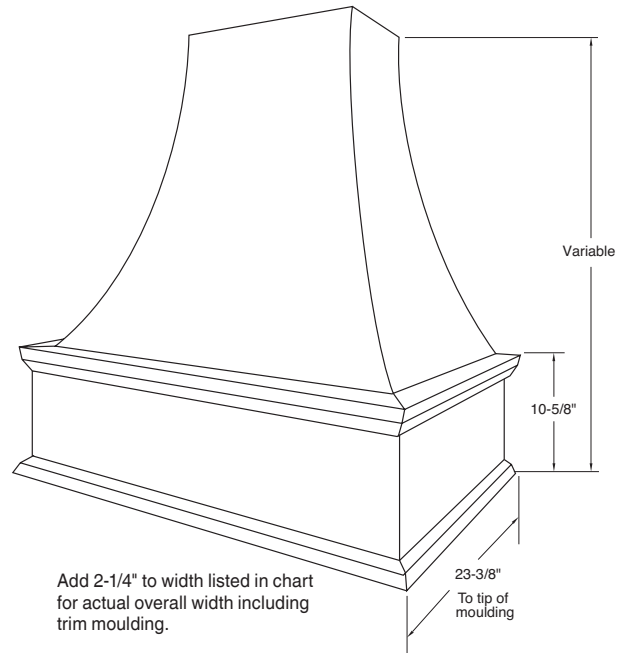

### E3 – Series Hood

- E3-Series hoods are not trimmable. Specific heights available through Special Designs.
- Lead-time 10 days unfinished, add 7 days for finishing.
- Fixed panel only.
- Moulding package not available.
- Available in Alder, Cherry, Hard Maple, PGHM Hybrid, Red Oak, Walnut and Quarter Sawn White Oak.
- **Custom sizes available through Special Designs.**

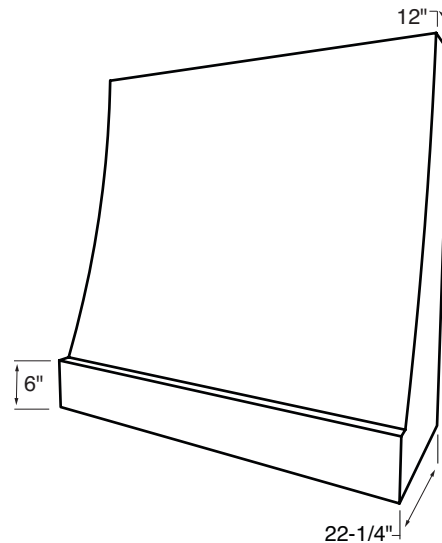

Height	E3-Series					
	Part Number					
24"	E3-30x24	E3-36x24	E3-42x24	E3-48x24	E3-54x24	E3-60x24
30"	E3-30x30	E3-36x30	E3-42x30	E3-48x30	E3-54x30	E3-60x30
36"	E3-30x36	E3-36x36	E3-42x36	E3-48x36	E3-54x36	E3-60x36
42"	E3-30x42	E3-36x42	E3-42x42	E3-48x42	E3-54x42	E3-60x42



## Stanisci Design Range Hoods (continued)

### Z200 – Series Hood

- Z200 - Series is a transitional hood designed to be mounted to the wall and adjacent cabinets.
- Lead-time 10 days unfinished, add 7 days for finishing.
- Fixed panel standard. Removable front optional (rear box increases to 16").
- Only available with Basic Moulding Package.
- Available in Alder, Cherry, Hard Maple, PGHM Hybrid, Red Oak, Walnut and Quarter Sawn White Oak.
- **Custom sizes available through Special Designs.**

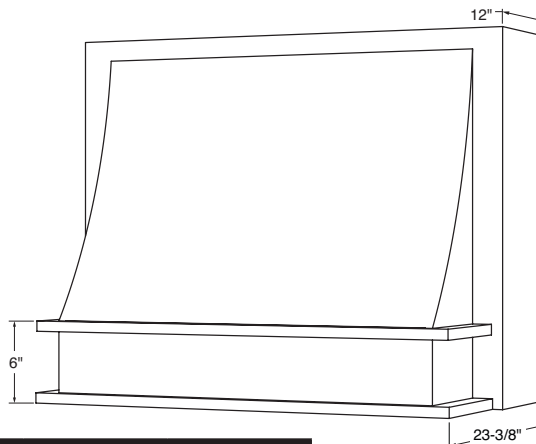

Height	Z200-Series					
	Part Number					
30"	Z200-33x30	Z200-39x30	Z200-45x30	Z200-51x30	Z200-57x30	Z200-63x30
36"	Z200-33x36	Z200-39x36	Z200-45x36	Z200-51x36	Z200-57x36	Z200-63x36
42"	Z200-33x42	Z200-39x42	Z200-45x42	Z200-51x42	Z200-57x42	Z200-63x42

### P – Series Hood

- P-Series is designed to be mounted to the wall and adjacent cabinets.
- Lead-time 10 days unfinished, add 7 days for finishing.
- Fixed panel standard. Removable front optional (rear box increases to 16").
- Available with Basic Moulding Package only.
- Available in Alder, Cherry, Hard Maple, PGHM Hybrid, Red Oak, Walnut and Quarter Sawn White Oak.
- **Custom sizes available through Special Designs.**

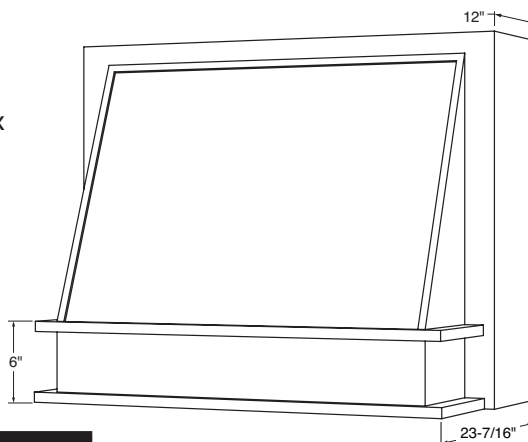

Height	P-Series					
	Part Number					
30"	P-33x30	P-39x30	P-45x30	P-51x30	P-57x30	P-63x30
36"	P-33x36	P-39x36	P-45x36	P-51x36	P-57x36	P-63x36
42"	P-33x42	P-39x42	P-45x42	P-51x42	P-57x42	P-63x42

## Stanisci Design Range Hoods (continued)

### FX – Series Hood

- FX – Series complements both contemporary and transitional styles and is designed to be either mounted as stand-alone or between cabinets.
- FX – Series hoods are not recommended to be cut down in the field – specify height at time of order.
- Lead-time 10 days unfinished, add 7 days for finishing.
- Fixed panel only.
- Moulding package not available.
- Available in Alder, Cherry, Hard Maple, PGHM Hybrid, Red Oak, Walnut and Quarter Sawn White Oak.

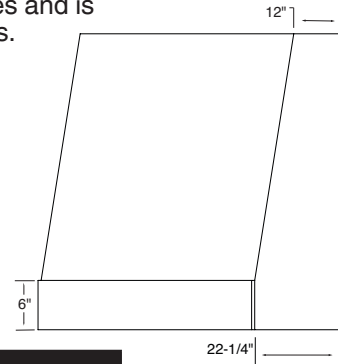

Height	FX-Series					
	Part Number					
24"	FX-30x24	FX-36x24	FX-42x24	FX-48x24	FX-54x24	FX-60x24
30"	FX-30x30	FX-36x30	FX-42x30	FX-48x30	FX-54x30	FX-60x30
36"	FX-30x36	FX-36x36	FX-42x36	FX-48x36	FX-54x36	FX-60x36
42"	FX-30x42	FX-36x42	FX-42x42	FX-48x42	FX-54x42	FX-60x42

### FXBPUP – Series Hood

- FXBPUP – Series is a transitional hood designed to be either mounted as stand-alone or between cabinets.
- Profile options –  
Framing Bead: Regular, Elite, Ogee, Square or F-1223.  
Panel Raise: Slant, G-Cove, RM, M-Bead or P-057.
- FXBPUP – Series hoods are not recommended to be cut down in the field – specify height at time of order.
- Lead-time 10 days unfinished, add 7 days for finishing.
- Removable panel only.
- Hoods with widths from 30"-48" will have two panels on top and two panels on the bottom. Hoods over 48" will have three panels on top and three panels on the bottom.
- Standard hood apron height is 6" with flat center panels or 8.75" for raised center panels.
- Available in Alder, Cherry, Hard Maple, PGHM Hybrid, Red Oak, Walnut and Quarter Sawn White Oak.
- **Custom sizes and panel configurations available through Special Designs.**

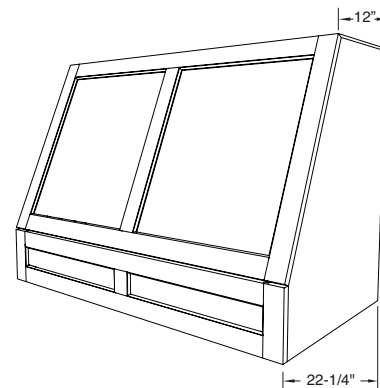

Height	FXBPUP-Series					
	Part Number					
24"	FXBPUP-30x24	FXBPUP-36x24	FXBPUP-42x24	FXBPUP-48x24	FXBPUP-54x24	FXBPUP-60x24
30"	FXBPUP-30x30	FXBPUP-36x30	FXBPUP-42x30	FXBPUP-48x30	FXBPUP-54x30	FXBPUP-60x30
36"	FXBPUP-30x36	FXBPUP-36x36	FXBPUP-42x36	FXBPUP-48x36	FXBPUP-54x36	FXBPUP-60x36
42"	FXBPUP-30x42	FXBPUP-36x42	FXBPUP-42x42	FXBPUP-48x42	FXBPUP-54x42	FXBPUP-60x42

## Stanisci Design Range Hoods (continued)

### FX2HW – Series Hood

- FX2HW-Series hoods are not recommended to be cut down in the field – specify height at time of order.
- Lead-time 10 days unfinished, add 7 days for finishing.
- Fixed panel standard. Removable top optional.
- Moulding package not available.
- Available in Alder, Cherry, Hard Maple, PGHM Hybrid, Red Oak, Walnut and Quarter Sawn White Oak.
- **Custom sizes available through Special Designs.**

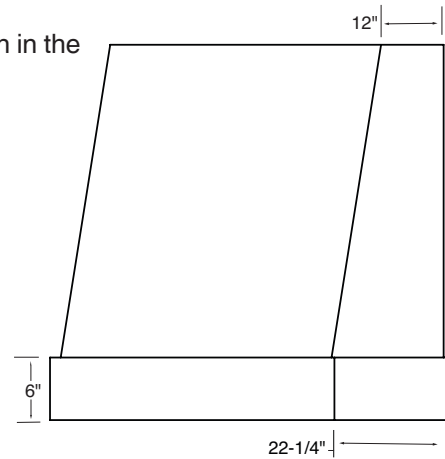

Height	FX2HW - Series					
	Part Number					
24"	FX2HW-30x24	FX2HW-36x24	FX2HW-42x24	FX2HW-48x24	FX2HW-54x24	FX2HW-60x24
30"	FX2HW-30x30	FX2HW-36x30	FX2HW-42x30	FX2HW-48x30	FX2HW-54x30	FX2HW-60x30
36"	FX2HW-30x36	FX2HW-36x36	FX2HW-42x36	FX2HW-48x36	FX2HW-54x36	FX2HW-60x36
42"	FX2HW-30x42	FX2HW-36x42	FX2HW-42x42	FX2HW-48x42	FX2HW-54x42	FX2HW-60x42
48"	FX2HW-30x48	FX2HW-36x48	FX2HW-42x48	FX2HW-48x48	FX2HW-54x48	FX2HW-60x48

### FX2PL – Series Hood

- FX2PL-Series hoods are not recommended to be cut down in the field – specify height at time of order.
- Lead-time 10 days unfinished, add 7 days for finishing.
- Fixed panel standard. Removable top optional.
- Available in Alder, Cherry, Hard Maple, PGHM Hybrid, Red Oak, Walnut and Quarter Sawn White Oak.
- **Custom sizes available through Special Designs.**

Add 2-1/4" to width listed in chart for actual overall width including trim moulding.

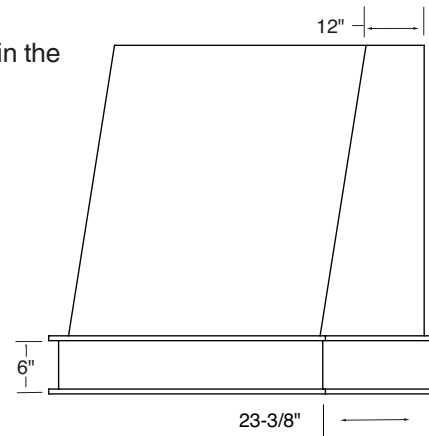

Height	FX2PL - Series					
	Part Number					
24"	FX2PL-30x24	FX2PL-36x24	FX2PL-42x24	FX2PL-48x24	FX2PL-54x24	FX2PL-60x24
30"	FX2PL-30x30	FX2PL-36x30	FX2PL-42x30	FX2PL-48x30	FX2PL-54x30	FX2PL-60x30
36"	FX2PL-30x36	FX2PL-36x36	FX2PL-42x36	FX2PL-48x36	FX2PL-54x36	FX2PL-60x36
42"	FX2PL-30x42	FX2PL-36x42	FX2PL-42x42	FX2PL-48x42	FX2PL-54x42	FX2PL-60x42
48"	FX2PL-30x48	FX2PL-36x48	FX2PL-42x48	FX2PL-48x48	FX2PL-54x48	FX2PL-60x48